



CHINMORE INDUSTRY CO., LTD

Specification

1. Product Type: 4G/LTE Antenna

2. Chinmore Model No: C09-1+174DS+SMA M

3. Frequency: 690~2700 MHz

4. Connector: SMA M

※RoHS Compliant

Cable	RG174U/DS	Frequency	690~960MHz	3M Sticker	1.2mm	<div style="border: 1px solid black; padding: 5px; text-align: center;"> ROHS ISO 9001 ISO 14001 </div>
OD	∅2.7±0.2mm		1770~2700MHz		PK-L15.0X117B-023	
Cover	Black (黑)	4G/LTE	C09-1(800M)			
SMA M	Gold (金)	Impedance	50Ω	P.C 板	PB-92800FR4-004	

注意：需另附酒精棉片

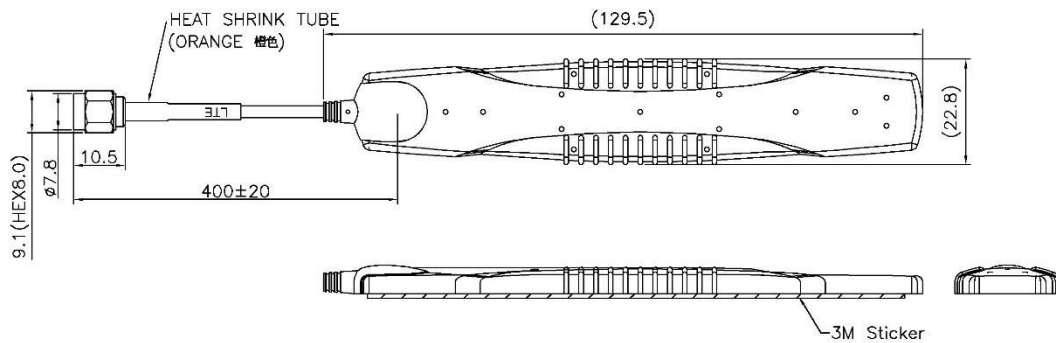

Material:		Treatment:		竣茂工業有限公司 Chinmore Industry CO .LTD			
Drawer	Design	Aprov	Tolerance	Unit: mm		TITLE	SMA M+174/DS+C09-1
			X=±0.5	Ver: A	Scale 1:1	Model NO	
			.X=±0.2	File NO: QR0402	Drawing NO	100-27049-013	
			.XX=±0.1				
			.XXX=±0.05				

Frequency (MHz)	Return Loss (dB)	VSWR
690	-8.58	1.98
824	-9.19	1.92
960	-23.41	1.17
1710	-11.90	1.64
1880	-18.62	1.27
2170	-6.38	2.85
2400	-11.24	1.76
2600	-15.43	1.38
2700	-20.09	1.21

Test Data (Return Loss & VSWR)

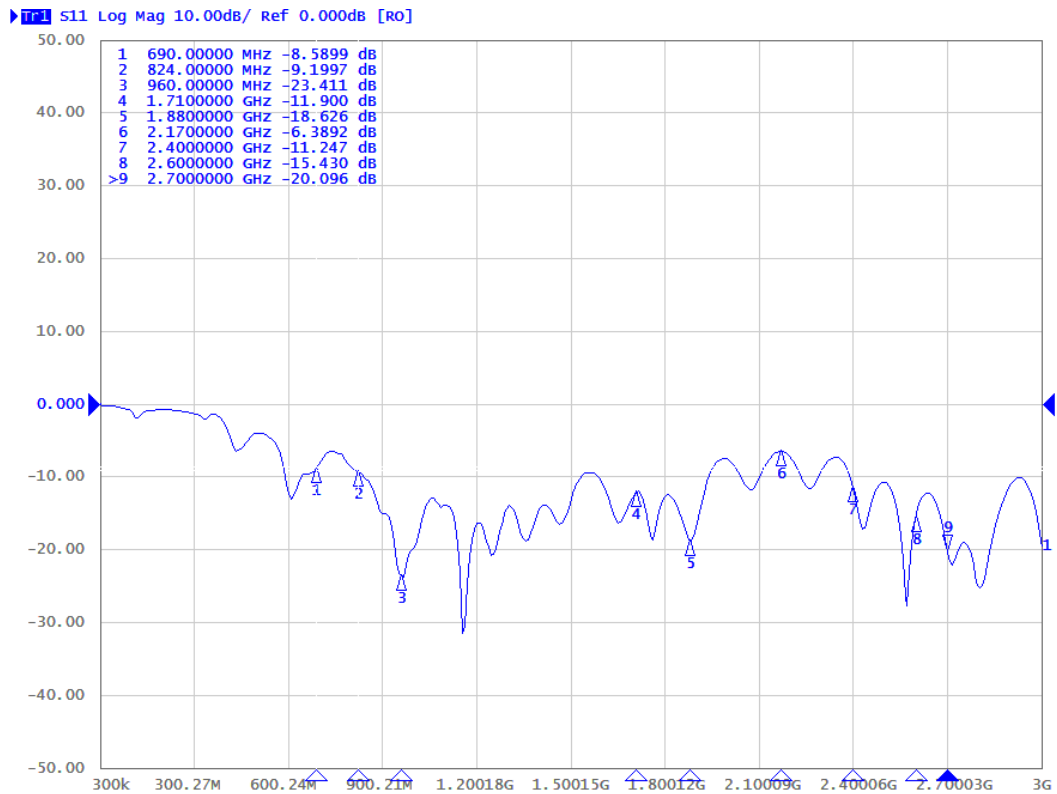

► S11 SWR 1.000/ Ref 1.000 [RO]

