

未注公差/General tolerances(mm)														
0	>3	>6	>10	>18	>30	>50	>80	>120	>180	>250	>315	>400	0.1/10 ±Z	
~3	~6	~10	~18	~30	~50	~80	~120	~180	~250	~315	~400	~500		
±0.12	±0.18	±0.22	±0.26	±0.31	±0.37	±0.57	±0.80	±0.93	±1.05	±1.15	±1.60	±2.20	±2.50	

View A

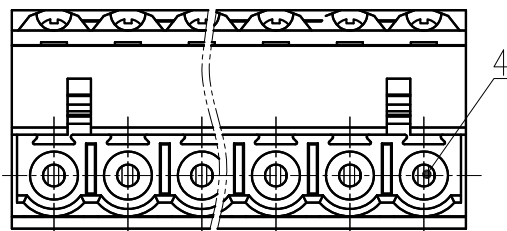

4

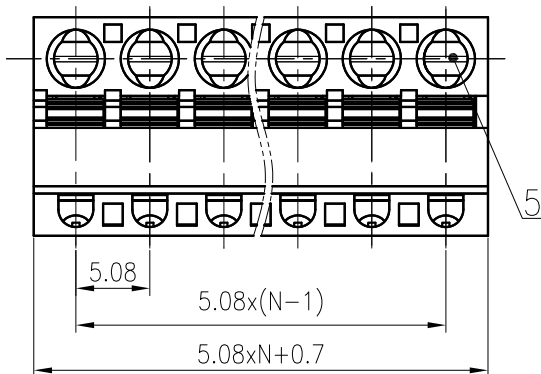

5

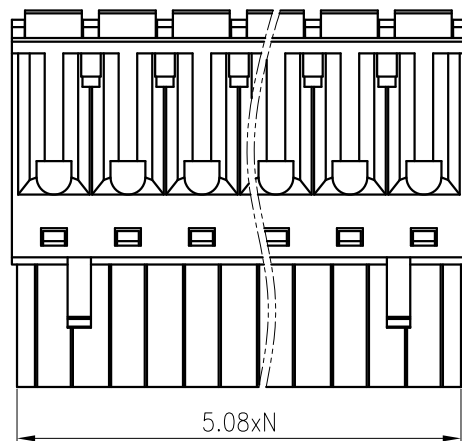

↑ A

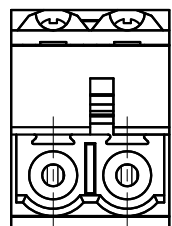
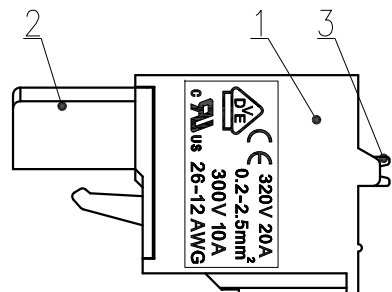
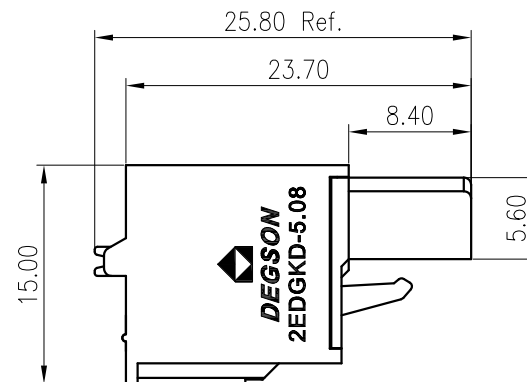

5	Spring	Stainless steel	/
4	Clamp	Copper alloy	Sn Plated
3	Button	PA66	UL94V-0
2	Cover	PA66	UL94V-0
1	Housing	PA66	UL94V-0

ITEM	NAME OF PART	MATERIAL	NOTES	
UL 标准/UL Standard:		B	C	D
额定电压/电流/Rated Voltage(V)/Current(A)		300/10	/	300/10
IEC 标准/IEC Standard:				
过压类别/Overvoltage Category/污染等级/Pollution Degree		III/3	III/2	II/2
额定电压/电流/Rated Voltage(V)/Current(A)		/	320/20	/
额定脉冲电压(KV)/Rate Impulse Voltage(KV)		/	4	/
线径范围(硬线和软线)/Wire Range(rigid and flexible)(mm <sup>2</sup> /AWG)		0.2~2.5/26~12		
间距/Pitch(mm)/线数范围/Poles		5.08/N=02~24P		
剥线长度/Stripping length(mm)		9~10		
使用温度范围/Operating temperature(°C)		-40~+105		
符合RoHS环保要求/Conform to RoHS		Yes		

MATERIAL:		SURFACE: /	
MAT NO.:	/	宁波高松电子有限公司 NINGBO DEGSON ELECTRICAL CO., LTD	
STATUS:	/		
APPD:	Li GL 2020.05.26	NAME: 2EDGKD-5.08-XXP-1Y-00A(H)	
CHKD:	Ma EK 2020.05.26	DRAWING NO.: 2EDGKD-5.08-C01	
DRFT:	ZDF 2018.02.27	REV	T1
⊕	SIZE: A4	TYPE: CUSTOMER DRAWING	SCALE: 2:1 SHEET 1/1

REV	ECN	DESCRIPTION	DRFT	DATE