

02P

03P

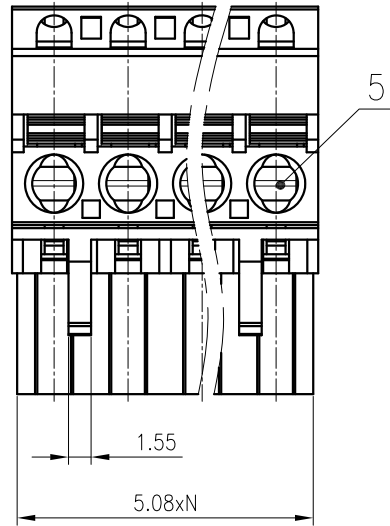

5

1.55

5.08xN

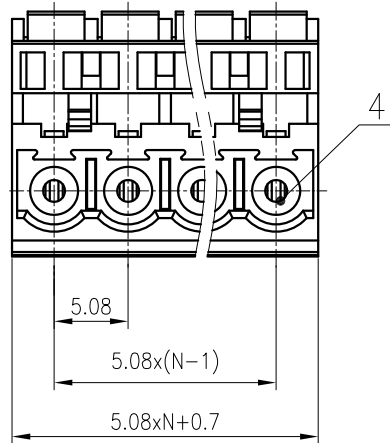
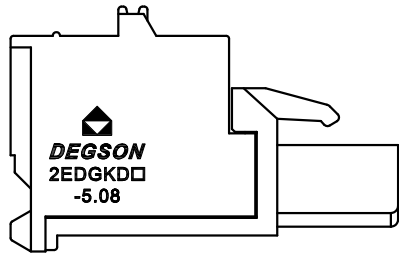

4

5.08

5.08x(N-1)

5.08xN+0.7

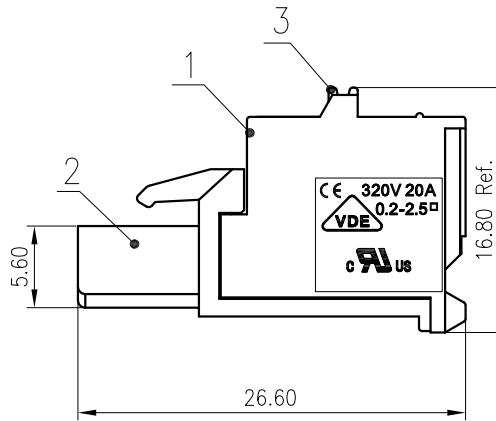

1

3

5.60

26.60

16.80 Ref.

未注公差/General tolerances(mm)												0.1/10	
0	>3	>6	>10	>18	>30	>50	>80	>120	>180	>250	>315		>400
~3	~6	~10	~18	~30	~50	~80	~120	~180	~250	~315	~400	~500	~500
±0.12	±0.18	±0.22	±0.26	±0.31	±0.37	±0.57	±0.80	±0.93	±1.05	±1.15	±1.60	±2.20	±2.50

ITEM	NAME OF PART	MATERIAL	NOTES
5	Spring	Stainless steel	
4	Clamp	Copper Alloy	Sn Plated
3	Button	PA66	UL94V-0
2	Cover	PA66	UL94V-0
1	Housing	PA66	UL94V-0

ITEM	NAME OF PART	MATERIAL	NOTES
UL 标准/UL Standard:			
额定电压/电流/Rated Voltage(V)/Current(A)		B	C D
		300/10	/ 300/10
EC 标准/IEC Standard:			
过压类别/Overvoltage Category/污染等级/Pollution Degree		III/2	
额定电压/电流/Rated Voltage(V)/Current(A)		320/20	
额定脉冲电压(KV)/Rate Impulse Voltage(KV)		4.0	
线径范围(硬线和软线)/Wire Range(rigid and flexible)(mm ² /AWG)		0.2~2.5/26~12	
间距/Pitch(mm)/线数范围/Poles		5.08/02~24P	
剥线长度/Stripping length(mm)		9~10	
使用温度范围/Operating temperature(°C)		-40~+105	
符合RoHS环保要求/Conform to RoHS		Yes	
标准颜色编号/Standard color number:		PANTONE / RAL	

MATERIAL:	/	SURFACE:	/
-----------	---	----------	---

MAT NO.:	/	宁波高松电子有限公司 NINGBO DEGSON ELECTRICAL CO., LTD	
STATUS:	/		
APPD:	LiGL 2020.06.13		
CHKD:	MaEK 2020.06.13		
DRFT:	LongHM 2019.01.17	NAME:	2EDGKDA-5.08-XXP-1Y-00A(H)
DRAWING NO.: 2EDGKDA-5.08-C01		REV:	T1
TYPE: CUSTOMER DRAWING		SCALE: 2:1	SHEET 1/1

REV	ECN	DESCRIPTION	DRFT	DATE