

公差/General tolerances(mm)		公差/General tolerances(mm)	
0	>3	>6	>10
~	~	~	~
3	6	10	18
±0.12	±0.18	±0.22	±0.26
±0.31	±0.37	±0.57	±0.80
±0.93	±1.05	±1.15	±1.60
±2.20	±2.50	±2.50	±2.50
±2	±2	±2	±2

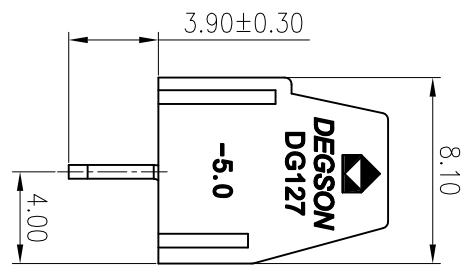

PCB LAYOUT

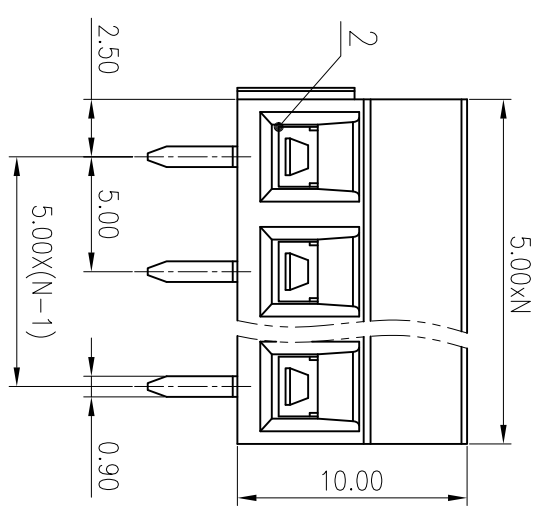
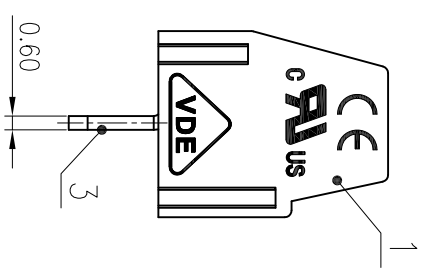
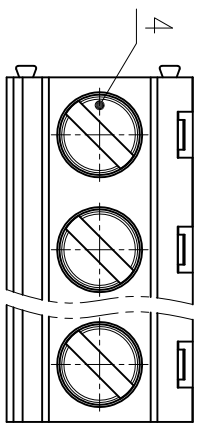
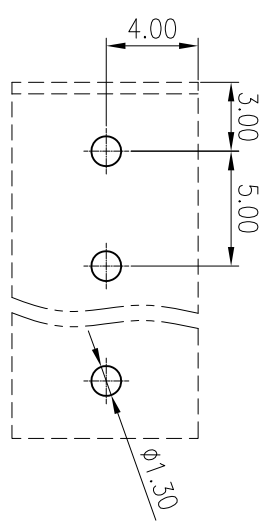

4	Screw	Steel	M3/Zn Plated
3	Pin header	Copper alloy	Sn Plated
2	Cage	Copper alloy	M3/Ni Plated
1	Housing	PA66	UL94V-0
ITEM	NAME OF PART	MATERIAL	NOTES
UL 标准/UL Standard:	B	C	D
额定电压/Rated Voltage(V)/Current(A)	300/12	/	/
IEC 标准/IEC Standard:			
过压类别/Overvoltage Category/污染等级/Pollution Degree	III/2		
额定电压/电流/Rated Voltage(V)/Current(A)	250/15		
工频耐压/Withstanding Voltage(V/Min)	AC2000		
螺丝扭矩/Torque Tightening(N·m/Lb·in)	M3: 0.34/3.04 ≥03P 0.5/4.43		
使用温度范围/Operating temperature(°C)	0.75~1.5/26~14		
柔软范围(硬线和软线)/Wire Range(rigid and flexible)(mm²/AWG)	5.00/N=02~24P		
间距/Pitch(mm)/线数范围/Poles	6~7		
剥线长度/Stripping length(mm)	-40~+105		
使用温度范围/Operating temperature(°C)	-40~+105		
符合RoHS环保要求/Conform to RoHS	Yes		

MATERIAL:	/		
MAT NO.:	/		
STATUS:	/		
APPD:	LanCH	2020.03.17	
CHKD:	YuJZ	2020.03.17	
DRFT:	Joy.z	2017.07.22	
NAME:	NINGBO DEGSON ELECTRICAL CO., LTD		
DRAWING NO.:	DG127-5.0-C32	REV	T1
TYPE:	CUSTOMER DRAWING	SCALE:	3:1 SHEET 1/1

REV	ECN	DESCRIPTION	DRFT	DATE