

未注公差/General tolerances(mm)												D 0.1/10		
0 ~ 3	>3 ~ 6	>6 ~ 10	>10 ~ 18	>18 ~ 30	>30 ~ 50	>50 ~ 80	>80 ~ 120	>120 ~ 180	>180 ~ 250	>250 ~ 315	>315 ~ 400		>400 ~ 500	>500
±0.12	±0.18	±0.22	±0.26	±0.31	±0.37	±0.57	±0.80	±0.93	±1.05	±1.15	±1.60	±2.20	±2.50	±2'

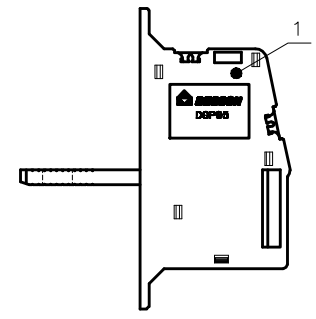
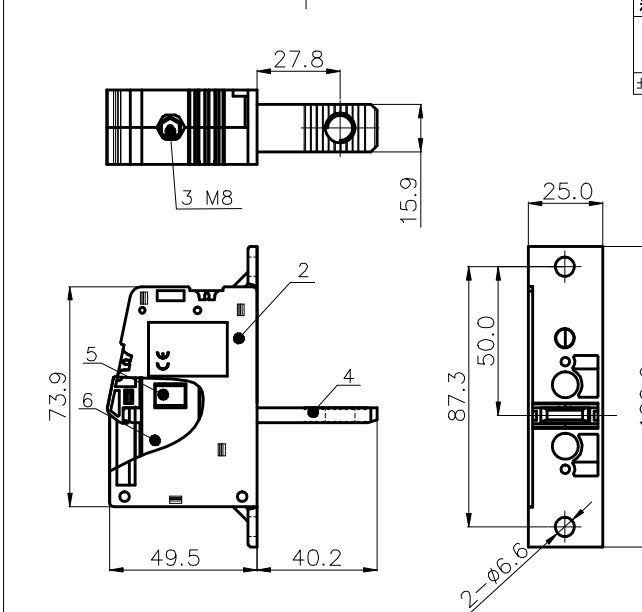
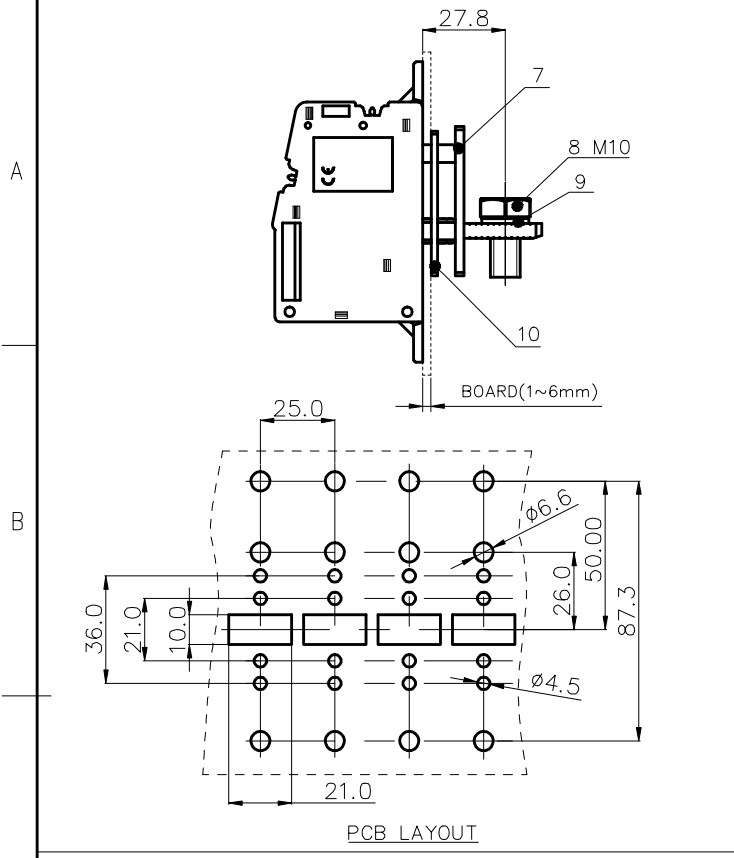

ITEM	NAME OF PART	MATERIAL	NOTES
10	Antivibration Pad	EVA	Black
9	Lock Washer	Steel	Zn Plated
8	Screw2	Steel	Zn Plated
7	Housing3	PA66	UL94V-0
6	Gage Iron	Spcc	Zn Plated
5	Gage Copper Alloy	Copper alloy	Ni Plated
4	Current Carrier	Copper	Sn Plated
3	Screw1	Steel	Zn Plated
2	Housing2	PA66	UL94V-0
1	Housing1	PA66	UL94V-0

REV	ECN	DESCRIPTION	DRFT	DATE

MATERIAL: /	SURFACE: /		
MAT NO.: /	宁波高松电子有限公司 NINGBO DEGSON ELECTRICAL CO., LTD		
STATUS: /			
APPD: /	NAME: DGP95-01P-1Y-00A(H)		
CHKD: /	DRAWING NO.: DGP95-C01		
DRFT: WWF 2016.05.27	REV	T0	
SIZE: A4 $\frac{mm}{inch}$	TYPE: CUSTOMER DRAWING	SCALE: 2:1	SHEET 1/1