

Product Specifications

Customer	Standard
Description	2.13" TFT DISPLAY
Model Name	DVGDTL0213T21
Date	2024/05/16
Revision	3.0

	Design Engineering		
	Approval	Check	Design
			

Contents

Revision History

Contents

- 1. General Description***
- 2. Mechanical Drawing***
- 3. Pin Description***
- 4. Electrical Characteristics***
- 5. Optical characteristics***
- 6. Reliability***
- 7. Package Specifications***
- 8. Precaution Relating Product Handling***
- 9. Warranty***
- 10. Notice***

1. General Description

1.1 Description

GDTL0213T21 is a 122X250 dot-matrix TFT LCD module. This module is composed of a TFT LCD Panel, driver ICs, FPC.

1.2 Features

NO.	Item	Contents	Unit
1	LCD Size	2.13	inch
2	Display Mode	Mono TFT/Normally White/ Reflective	-
3	Resolution	122(H) x 250(V)	pixels
4	Dot pitch	0.194(H) x 0.194(V)	mm
5	Active area	23.668(H) x 48.5(V)	mm
6	Module size	27.07(H) x 56.2(V) x1.1(D)	mm
7	Interface	4 Line SPI	-
8	Drive IC	ST7305	-
9	Operating Temp.	-20°C~ + 70°C	°C
10	Storage Temp.	-30°C~+ 80°C	°C
11	Weight	3.3	g

2. Mechanical Drawing

Item	Date	Remark
A	20220607	Original Drawing

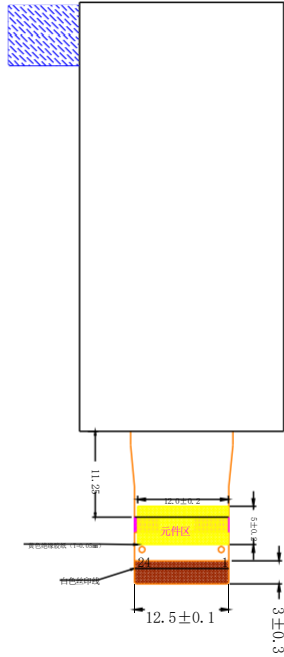
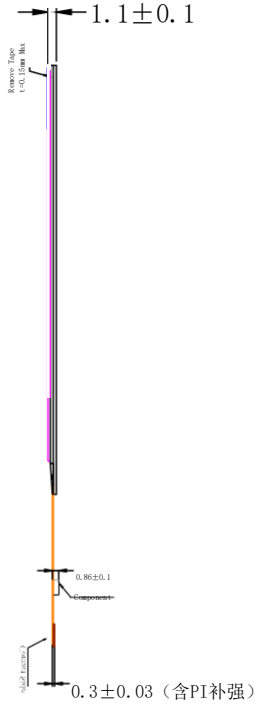
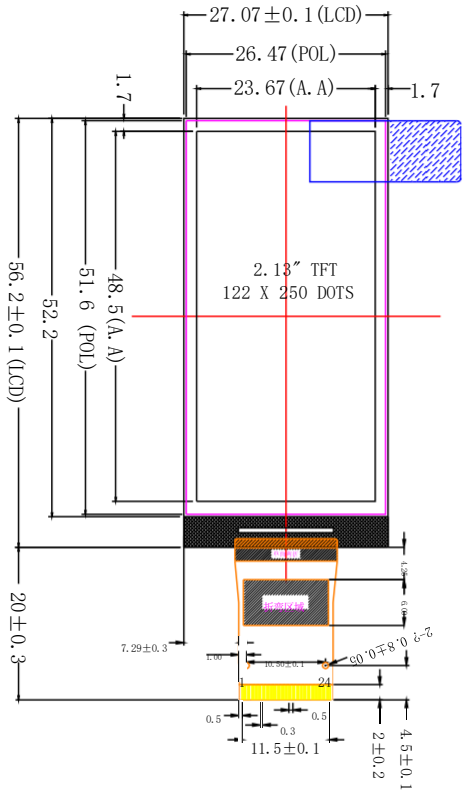

PIN	ASSIGNMENT
1	NC
2	NC
3	NC
4	VMREF
5	VCOMH
6	NC
7	NC
8	IF1
9	NC
10	RESET
11	D_CX
12	CS
13	SCL
14	SDA
15	VDD
16	VDD
17	GND
18	VSL
19	VSH
20	VGL
21	NC
22	VGH
23	NC
24	AVDD

IF1	VCC 3-line
	GND 4-line

NOTES:

1. DISPLAY TYPE: 2.13" Momo TFT
2. DISPLAY MODE: Normally White/Reflective Type
3. DRIVER IC: ST7305
4. OPERATING TEMP.: -20° C ~ 70° C
5. STORAGE TEMP.: -30° C ~ 80° C
6. UNMARKED TOLERANCE: ± 0.2
7. 建议机壳开窗可视区比 LCD A. A区单边大 0.3mm
8. 产品符合ROHS标准

Customer Approval Signature	Title				Drawing Number		Rev	
	DVGDTL0213T21				2.13" TFT		B	
Material				Soda Lime / Polyimide				
Scale				Sheet		Size		
1:1				1 of 1		A3		
Unless Otherwise Specified		Unit		mm		Title		
General Roughness		Tolerance		Dimension		Angle		
± 0.2		± 1		± 0.2		± 1		
By		Date		E. E.		Panel / E.		
Letter		20220607		P. M.				

3. Pin Definition

FPC Connector is used for the module electronics interface.

NO.	Symbol	Description
1	NC	No Connect.
2	NC	No Connect.
3	NC	No Connect.
4	VMREF	Power output pin for analog driver
5	VCOMH	VCCI is the power source of digital circuits
6	NC	No Connect.
7	NC	No Connect.
8	IF1	IF1=GND, interface mode select 4-line. IF1=VDD, interface mode select 3-line .
9	NC	No Connect.
10	RESET	Reset input pin. When LCD_RES is “L”, internal initialization procedure is executed
11	D_CX	Display data/command selection pin in 4-line serial interface.
12	CS	Chip selection pin; Low enable, high disable.
13	SCL	This pin is used to be serial interface clock
14	SDA	SPI interface input/output pin. the data is latched on the rising edge of the SCL signal.
15	VDD	Power Supply (Analog). VCCI=2.55V-3.3V
16	VDD	Power Supply (Analog). VCCI=2.55V-3.3V
17	GND	Power Ground
18	VSL	Power output pin for analog driver
19	VSH	Power output pin for analog driver
20	VGL	Power output (Negative) pin for gate driver
21	NC	No Connect.
22	VGH	Power output (Positive) pin for gate driver
23	NC	No Connect.
24	AVDD	Power output pin for analog driver

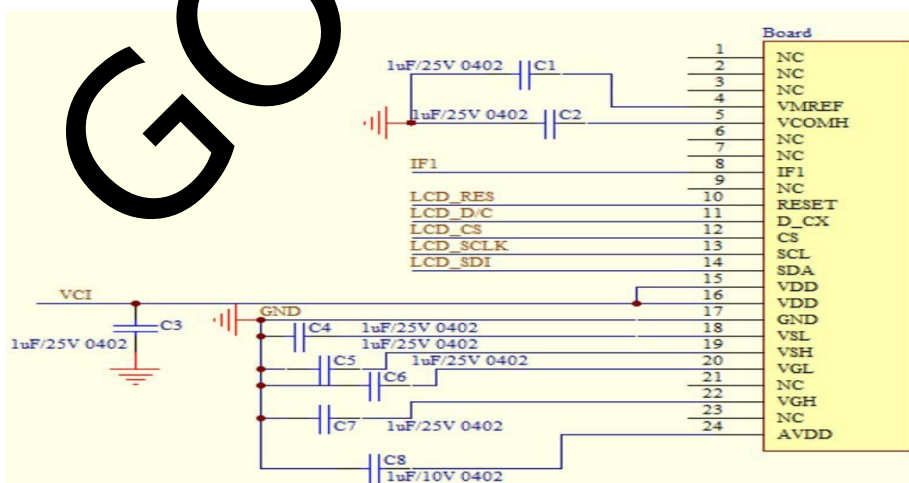

IF1=GND, interface mode select 4-line. IF1=VDD, interface mode select 3-line

4. Electrical Characteristics

4.1 Absolute Maximum Ratings

Parameter	Symbol	Min	MAX	Unit	Notes
Supply Voltage (I/O)	VDD	-0.3	4.0	V	
Analog Supply Voltage	IOVCC	-0.3	4.0	V	
Logic Input Voltage	VIN	-0.3	VDDIO+0.5	V	
Operation Temperature	Top	-20	70	°C	
Storage Temperature	Tst	-30	80	°C	

4.2 Operating Conditions

Parameter	Symbol	Min	TYP	MAX	Unit	Notes
System Voltage	VDD	2.55	2.8	3.3	V	
Interface Operation Voltage	IOVCC	1.65	1.8	3.3	V	
Gate Driver High Voltage	VGH	8	-	13.5	V	
Gate Driver Low Voltage	VGL	-10	-	-5	V	
Input voltage 'H' level	VIH	0.7VDDI/IOVCC	-	VDDI/IOVCC	V	
Input voltage 'L' level	VIL	VSS	-	0.3VDDI/IOVCC	V	
Output voltage 'H' level	VOH	0.8VDDI/IOVCC	-	VDDI/IOVCC	V	
Output voltage 'L' level	VOL	VSS	-	0.2VDDI/IOVCC	V	

4.3 Characteristics

Item of Characteristics	Symbol	Min	TYP	MAX	Unit	Condition
Operating Current for VDD	IDD	-	14.3	-	uA	耗电持续1.8S,平均值

Note: Operating Current for VDD Test Report

4.3.1 平台功耗 (不带屏)



平均功耗：1.9 微安

4.3.2 整机功耗 (带屏幕)

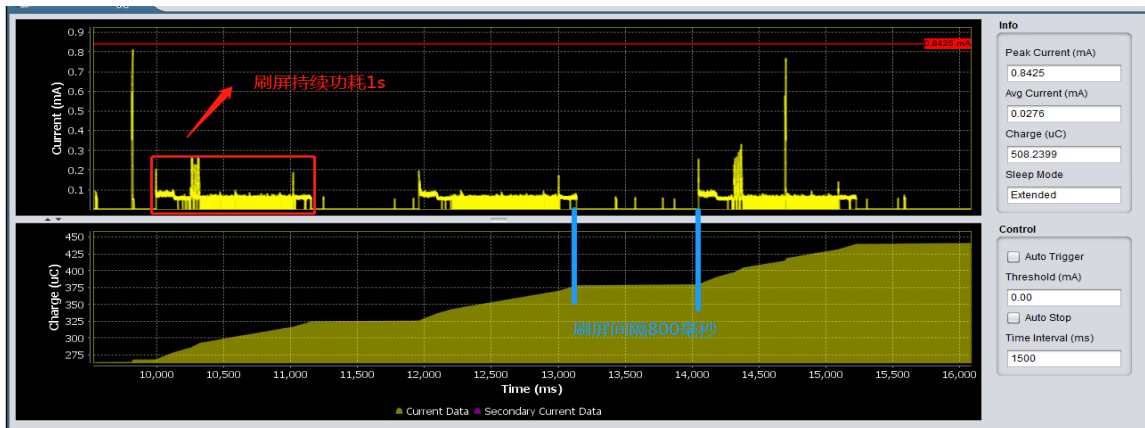

平均功耗：27.6 微安

分析：刷屏间隔 800 毫秒，每次刷屏耗电持续 1s

测试结论：屏幕功耗为 $27.6 - 1.9 = 25.7$ 微安。

4.4 AC Timing Characteristic of The LCD

Please refer to the driver ST7305 IC specification

5. OPTICAL CHARACTERISTICS

Item	Symbol	Measuring Conditions		Min.	Typ.	Max.	Unit	Remark
Viewing Angle	θ	$\phi = 0^\circ$	25 °C	-	65	-	Deg	Note1
		$\phi = 180^\circ$	25 °C	-	65	-		
	θ	$\phi = 90^\circ$	25 °C	-	65	-		
		$\phi = 270^\circ$	25 °C	-	65	-		
Reflectance	T%	--	-	-	40	-	%	
Contrast ration	CR	--	25 °C	-	15	-	--	Note2
Response Time	Tr+Tf	$\theta = 0^\circ$ $\phi = 0^\circ$	25 °C	-	-	-	ms	Note3
Color of CIE Coordinate	White	X	25 °C	-	-	-	--	BM-7A
		Y	25 °C	-	-	-		
	Red	X	25 °C	-	-	-		
		Y	25 °C	-	-	-		
	Green	X	25 °C	-	-	-		
		Y	25 °C	-	-	-		
Blue	X	25 °C	-	-	-			
	Y	25 °C	-	-	-			

Note 1 Definition of Viewing Angle:

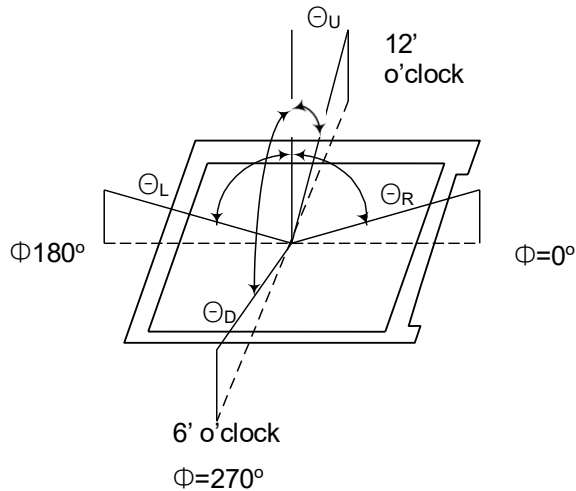

Note 2 Definition of Contrast Ratio (CR) :

measured at the center point of panel

$$CR = \frac{\text{Luminance with all pixels white}}{\text{Luminance with all pixels black}}$$

Note 3 Definition of Response Time : Sum of Tr and Tf :

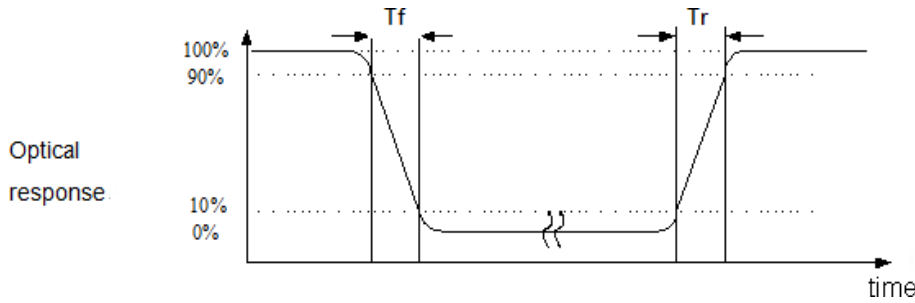

6. Reliability

Contents of Reliability Tests

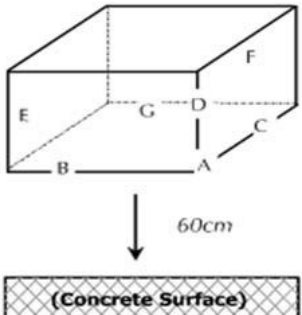
No.	Item	Conditions	Note
1	High Temperature Operation	70°C±2°C, 120 hrs	
2	Low Temperature Operation	-20°C±2°C, 120 hrs	
3	High Temperature Storage	80°C±2°C, 120 hrs	
4	Low Temperature Storage	-30°C±2°C, 120 hrs	
5	High Temperature /Humidity Operation	60°C±2°C, 90% RH, 120 hrs	
6	Temperature Cycling	-10°C→25°C→60°C→25°C→-10°C 30min 5min 30min 5min 30min 10 cycle.	
7	Vibration Test	Total fixed amplitude:1.5mm. Vibration Frequency:10~55Hz One cycle 60 seconds to 3 direction of X,Y,Z each 15 minutes.	
8	ESD Test	Air Discharge:Apple ±4KV with 5 times. Contact Discharge:Apple ±2KV with 5 times.	
9	Drop Test	To be measured after dropping from 60cm high on the concrete surface in packing state.  <i>Dropping method corner dropping:</i> <i>A corner: Once edge dropping.</i> <i>B, C, D edge: Once face dropping.</i> <i>E, F, G face: Once.</i>	

Note:

No charge on display and in operation under the following test condition.
 Condition:Unless otherwise specified,tests will be conducted under the following condition.
 Temperature:20°C±5°C.
 Humidity:65±5%RH.
 Tests will be not conducted under functioning state.

7. Package Specifications

Item		Quantity	
Module		1440	per Primary Box
Holding Trays	(A)	15	per Primary Box
Total Trays	(B)	16	per Primary Box (Including 1 Empty Tray)
Primary Box	(C)	1~4	per Carton (4 as Major / Maximum)

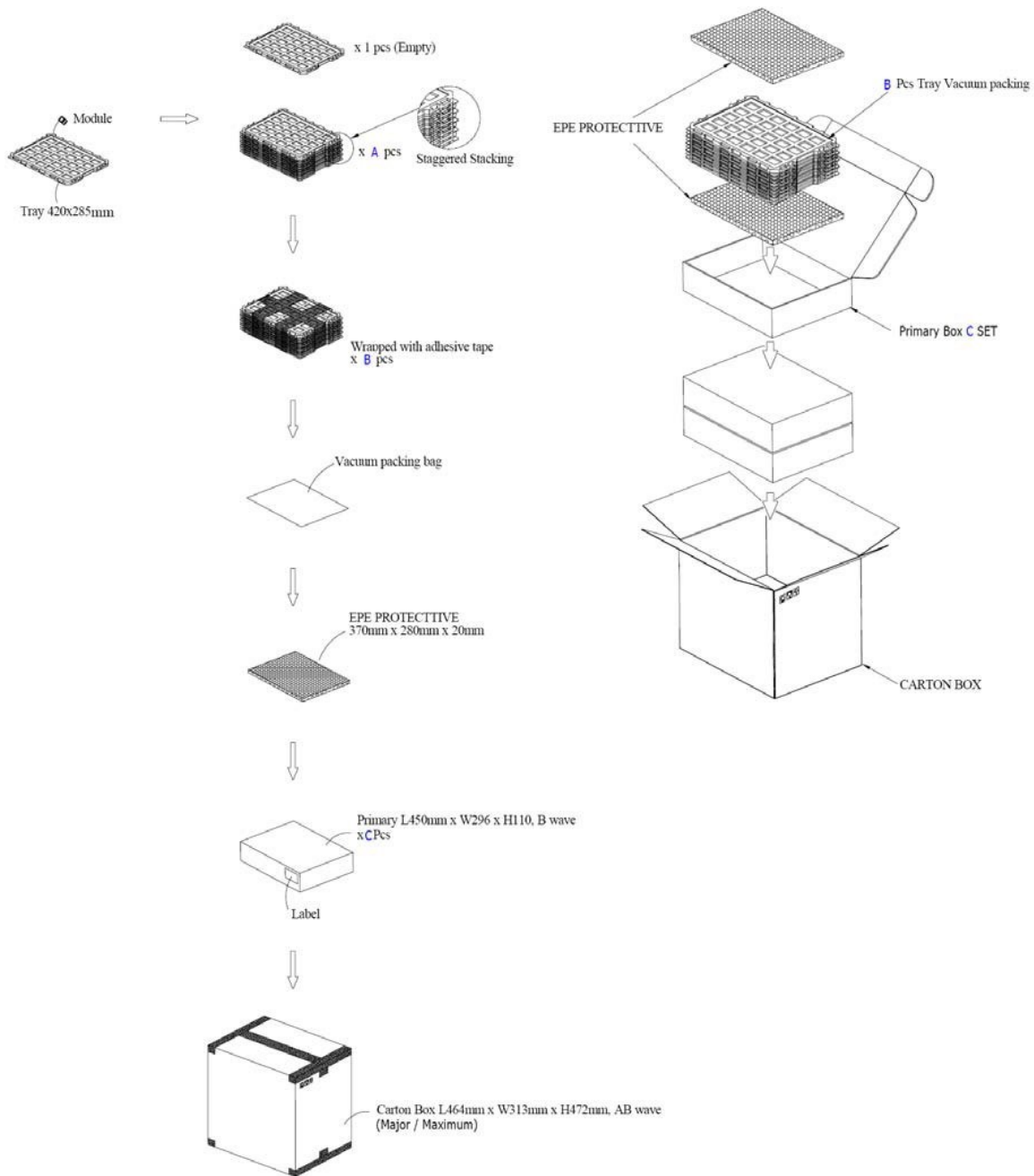

8. Precautions When Using These TFT Display Modules

8.1 Handling Precautions

- 1) Since the display panel is being made of glass, do not apply mechanical impacts such as dropping from a high position.
- 2) If the display panel is broken by some accident and the internal organic substance leaks out, be careful not to inhale nor lick the organic substance.
- 3) If pressure is applied to the display surface or its neighborhood of the TFT display module, the cell structure may be damaged and be careful not to apply pressure to these sections.
- 4) The polarizer covering the surface of the TFT display module is soft and easily scratched. Please be careful when handling the TFT display module.
- 5) When the surface of the polarizer of the TFT display module has soil, clean the surface. It takes advantage of by using following adhesion tape.
 - * Scotch Mending Tape No. 810 or an equivalent
 Never try to breathe upon the soiled surface nor wipe the surface using cloth containing solvent such as ethyl alcohol, since the surface of the polarizer will become cloudy. Also, pay attention that the following liquid and solvent may spoil the polarizer:
 - * Water
 - * Ketone
 - * Aromatic Solvents
- 6) Hold TFT display module very carefully when placing TFT display module into the system housing. Do not apply excessive stress or pressure to TFT display module. And, do not over bend the film with electrode pattern layouts. These stresses will influence the display performance. Also, secure sufficient rigidity for the outer cases.

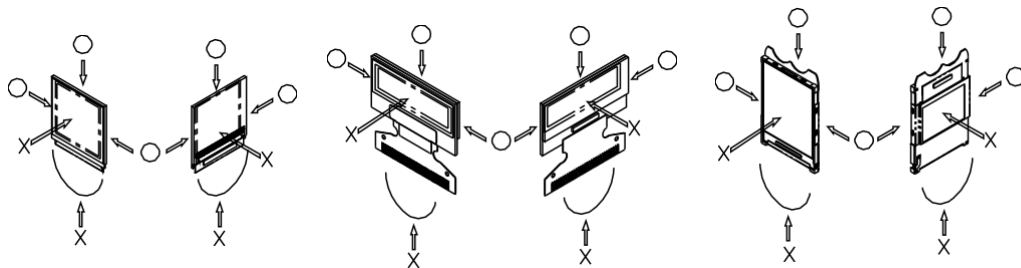

- 7) Do not apply stress to the driver IC and the surrounding molded sections.
- 8) Do not disassemble nor modify the TFT display module.
- 9) Do not apply input signals while the logic power is off.
- 10) Pay sufficient attention to the working environments when handling TFT display modules to prevent occurrence of element breakage accidents by static electricity.
 - * Be sure to make human body grounding when handling TFT display modules.
 - * Be sure to ground tools to use or assembly such as soldering irons.
 - * To suppress generation of static electricity, avoid carrying out assembly work under dry environments.
 - * Protective film is being applied to the surface of the display panel of the TFT display module. Be careful since static electricity may be generated when exfoliating the protective film.
- 11) Protection film is being applied to the surface of the display panel and removes the protection film before assembling it. At this time, if the TFT display module has been stored for a long period of time, residue adhesive material of the protection film may remain on the surface of the display panel after removed of the film. In such case, remove the residue material by the method introduced in the above Section 5).
- 12) If electric current is applied when the TFT display module is being dewed or when it is placed under high humidity environments, the electrodes may be corroded and be careful to avoid the above.

8.2 Storage Precautions

- 1) When storing TFT display modules, put them in static electricity preventive bags avoiding exposure to direct sun light nor to lights of fluorescent lamps. and, also, avoiding high temperature and high humidity environment or low temperature (less than 0°C) environments. (We recommend you to store these modules in the packaged state when they were shipped from Limoto technology Inc.)
At that time, be careful not to let water drops adhere to the packages or bags nor let dewing occur with them.
- 2) If electric current is applied when water drops are adhering to the surface of the TFT display module, when the TFT display module is being dewed or when it is placed under high humidity environments, the electrodes may be corroded and be careful about the above.

8.3 Designing Precautions

- 1) The absolute maximum ratings are the ratings which cannot be exceeded for TFT display module, and if these values are exceeded, panel damage may be happen.
- 2) To prevent occurrence of malfunctioning by noise, pay attention to satisfy the V_{IL} and V_{IH} specifications and, at the same time, to make the signal line cable as short as possible.
- 3) We recommend you to install excess current preventive unit (fuses, etc.) to the power circuit (V_{DD}). (Recommend value: 0.5A)
- 4) Pay sufficient attention to avoid occurrence of mutual noise interference with the neighboring devices.
- 5) As for EMI, take necessary measures on the equipment side basically.
- 6) When fastening the TFT display module, fasten the external plastic housing section.
- 7) If power supply to the TFT display module is forcibly shut down by such errors as taking out the main battery while the TFT display panel is in operation, we cannot guarantee the quality of this OEL display module.
- 8) The electric potential to be connected to the rear face of the IC chip should be as follows:
 - * Connection (contact) to any other potential than the above may lead to rupture of the IC.

8.4 Precautions when disposing of the TFT display modules

- 1) Request the qualified companies to handle industrial wastes when disposing of the TFT display modules. Or, when burning them, be sure to observe the environmental and hygienic laws and regulations.

8.5 Other Precautions

- 1) When an TFT display module is operated for a long of time with fixed pattern may remain as an after image or slight contrast deviation may occur.
Nonetheless, if the operation is interrupted and left unused for a while, normal state can be restored. Also, there will be no problem in the reliability of the module.
- 2) To protect TFT display modules from performance drops by static electricity rapture, etc., do not touch the following sections whenever possible while handling the TFT display modules.
 - * Pins and electrodes
 - * Pattern layouts such as the FPC
- 3) With this TFT display module, the TFT driver is being exposed. Generally speaking, semiconductor elements change their characteristics when light is radiated according to the principle of the solar battery. Consequently, if this TFT driver is exposed to light, malfunctioning may occur.
 - * Design the product and installation method so that the TFT driver may be shielded from light in actual usage.
 - * Design the product and installation method so that the TFT driver may be shielded from light during the inspection processes.
- 4) Although this TFT display module stores the operation state data by the commands and the indication data, when excessive external noise, etc. enters into the module, the internal status may be changed. It therefore is necessary to take appropriate measures to suppress noise generation or to protect from influences of noise on the system design.
- 5) We recommend you to construct its software to make periodical refreshment of the operation statuses (re-setting of the commands and re-transference of the display data) to cope with catastrophic noise.

9. Warranty:

The warranty period shall last twelve (12) months from the date of delivery. Buyer shall be completed to assemble all the processes within the effective twelve (12) months. Good Display shall be liable for replacing any products which contain defective material or process which do not conform to the product specification , applicable drawings and specifications during the warranty period . All products must be preserved , handled and appearance to permit efficient handling during warranty period . The warranty coverage would be exclusive while the returned goods are out of the terms above.

10. Notice:

No part of this material may be reproduces or duplicated in any form or by any means without the written permission of Good Display. we would reserve the right to make changes to this material without notice. . does not assume any liability of any kind arising out of any inaccuracies contained in this material or due to its application or use in any product or circuit and , further , there is no representation that this material is applicable to products requiring high level reliability , such as, medical products . Moreover , no license to any intellectual property rights is granted by implication or otherwise , and there is no representation or warranty that anything made in accordance with this material will be free from any patent or copyright infringement of a third party. This material or portions thereof may contain technology or the subject relating to strategic products under the control of Foreign Exchange and Foreign Trade Law of Taiwan and may require an export license from the Ministry of International Trade and Industry or other approval from another government agency.