

Product Specifications

Customer	Standard
Description	2.9" TFT DISPLAY
Model Name	GDTL029T51
Date	2024/05/16
Revision	3.0

	Design Engineering		
	Approval	Check	Design
			



- **Address:** B305 Youpinyishu no.68 - 518081 - Shenzhen (Guangdong) - China
- **Tel:** (86) 13632770721
- **Email:** info@devetechelectronics.com

Contents

Revision History

Contents

- 1. General Description***
- 2. Mechanical Drawing***
- 3. Pin Description***
- 4. Electrical Characteristics***
- 5. Optical characteristics***
- 6. Reliability***
- 7. Package Specifications***
- 8. Precaution Relating Product Handling***
- 9. Warranty***
- 10. Notice***

1. General Description

1.1 Description

DVGDTL029T51 is a 168 X 384 dot-matrix Reflective TFT LCD module. This module is composed of a TFT LCD backplate, driver ICs, FPC.

1.2 Features

NO.	Item	Contents	Unit
1	LCD Size	2.9	inch
2	Display Mode	Mono TFT/Normally White/ Reflective	-
3	Resolution	168(H) x 384(V)	pixels
4	Dot pitch	0.1732(H) x 0.17408(V)	mm
5	Active area	29.1(H) x 66.85(V)	mm
6	Module size	31.1(H) x 70.95(V) x0.8(D)	mm
7	Interface	4 Line SPI	-
8	Drive IC	ST7305	-
9	Operating Temp.	-20°C~ + 70°C	°C
10	Storage Temp.	-30°C~+ 80°C	°C
11	Weight	3.7	g

2. Mechanical Drawing

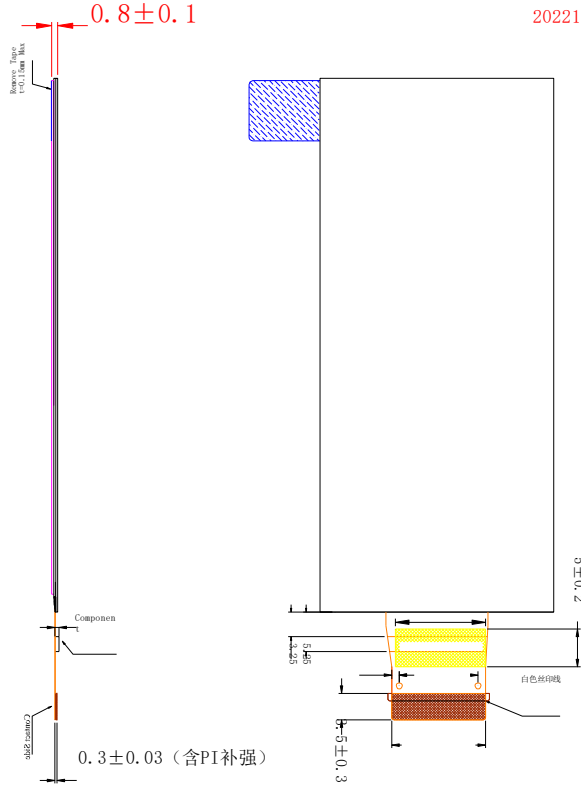
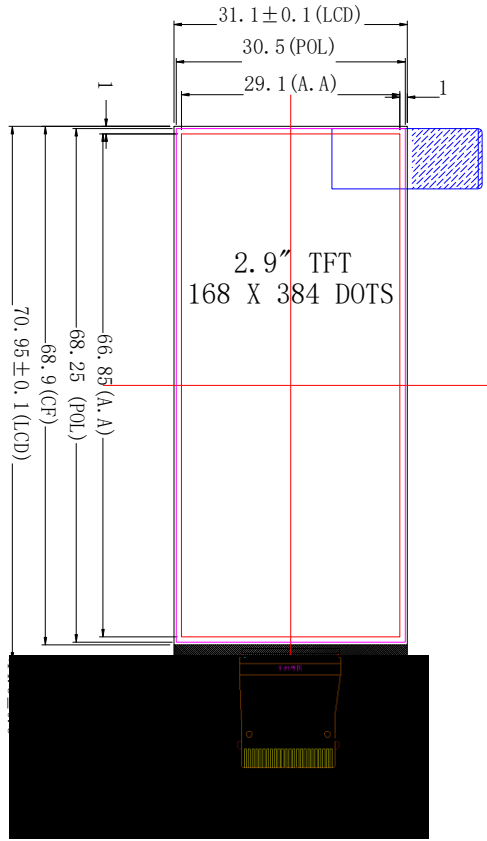

Item	Date	Remark
A		Original
20220812		Drawing
B		屏的厚度改薄为0.8mm
20221221		

LCM	Pin Assignment
NO	SYMBOL
1	NC
2	NC
3	NC
4	NC
5	VCC(I-O)
6	NC
7	NC
8	NC
9	TE
10	LCD RES
11	LCD D/C
12	LCD CS
13	LCD SCLK
14	LCD SDI
15	IOWCC
16	VCI
17	GND
18	VGH
19	NC
20	VIV
21	AVDD
22	VNV
23	NC
24	VGL

接口支持：4线SPI

NOTES:

1. [Redacted]
2. [Redacted] Type
3. [Redacted]
4. [Redacted]

Customer Approval
Signature

Drawing Number
2.9" TFT
Rev.
B

Unless Otherwise Specified		DVGTL029T51				Material	
Unit	mm	Title				Soda Lime / Polyimide	
General Roughness		Drawn	E E	Panel / E	P M		
Tolerance							

3. Pin Definition

FPC Connector is used for the module electronics interface.

NO.	Symbol	Description
1	NC	No Connect.
2	NC	No Connect.
3	NC	No Connect.
4	NC	No Connect.
5	VCC(I-0)	VCCI is the power source of digital circuits
6	NC	No Connect.
7	NC	No Connect.
8	NC	No Connect.
9	TE	Tearing effect signal is used to synchronize MCU to frame memory writing
10	LCD_RES	Reset input pin. When LCD_RES is “L”, internal initialization procedure is executed
11	LCD_D/C	Display data/command selection pin in 4-line serial interface.
12	LCD_CS	Chip selection pin;Low enable,high disable.
13	LCD_SCLK	This pin is used to be serial interface clock
14	LCD_SDI	SPI interface input/output pin. The data is latched on the rising edge of the SCL signal.
15	IOVCC	Power Supply(Digital). IOVCC=1.65V-3.3V
16	VCI	Power Supply(Analog). VCI=2.55V-3.3V
17	GND	Power Ground
18	VGH	Power output(Positive) pin for gate driver
19	NC	No Connect.
20	VIV	Power output pin for analog driver
21	AVDD	Power output pin for analog driver
22	VNV	Power output pin for analog driver
23	NC	No Connect.
24	VGL	Power output(Negative) pin for gate driver

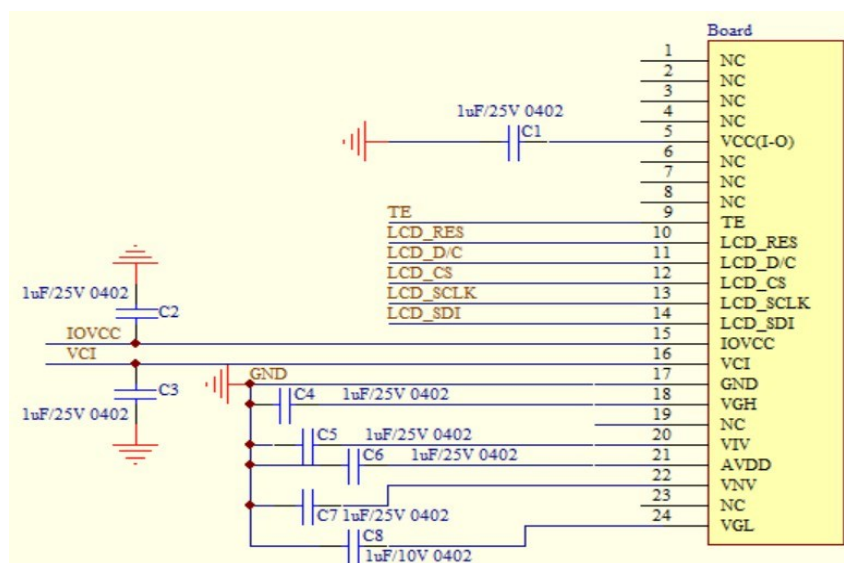

4. Electrical Characteristics

4.1 Absolute Maximum Ratings

Parameter	Symbol	Min	MAX	Unit	Notes
Supply Voltage (I/O)	VDD	-0.3	4.0	V	
Analog Supply Voltage	IOVCC	-0.3	4.0	V	
Logic Input Voltage	VIN	-0.3	VDDIO+0.5	V	
Operation Temperature	Top	-20	70	°C	
Storage Temperature	Tst	-30	80	°C	

4.2 Operating Conditions

Parameter	Symbol	Min	TYP	MAX	Unit	Notes
System Voltage	VDD	2.55	2.8	3.3	V	
Interface Operation Voltage	IOVCC	1.65	1.8	3.3	V	
Gate Driver High Voltage	VGH	8	-	13.5	V	
Gate Driver Low Voltage	VGL	-10	-	-5	V	
Input voltage 'H' level	VIH	0.7VDDI/IOVCC	-	VDDI/IOVCC	V	
Input voltage 'L' level	VIL	VSS	-	0.3VDDI/IOVCC	V	
Output voltage 'H' level	VOH	0.8VDDI/IOVCC	-	VDDI/IOVCC	V	
Output voltage 'L' level	VOL	VSS	-	0.2VDDI/IOVCC	V	

4.3 Characteristics

Item of Characteristics	Symbol	Min	TYP	MAX	Unit	Condition
Operating Current for VDD	IDD	-	14.3	-	uA	耗电持续1.8S,平均值

Note: Operating Current for VDD Test Report

4.3.1 Basic power consumption (without screen)

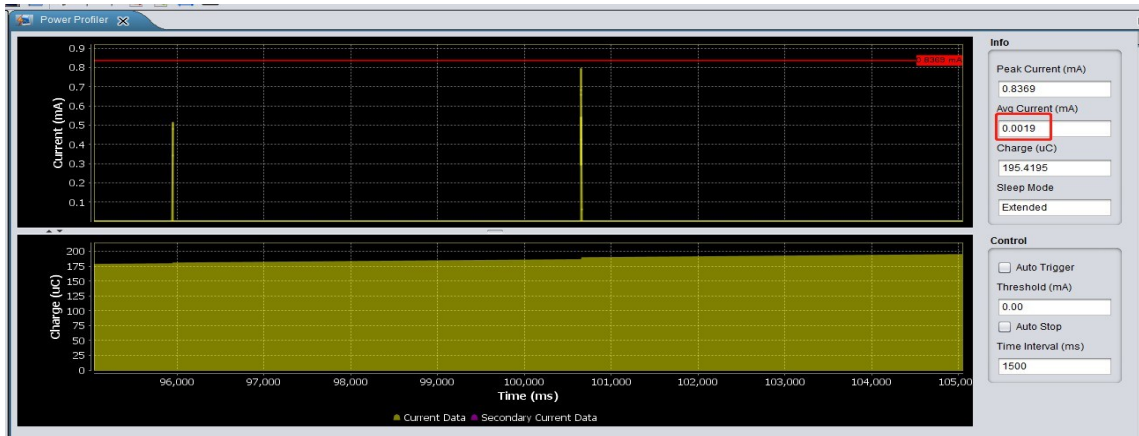

Average power consumption: 1.9 mA

4.3.2 Whole Power consumption (with screen)

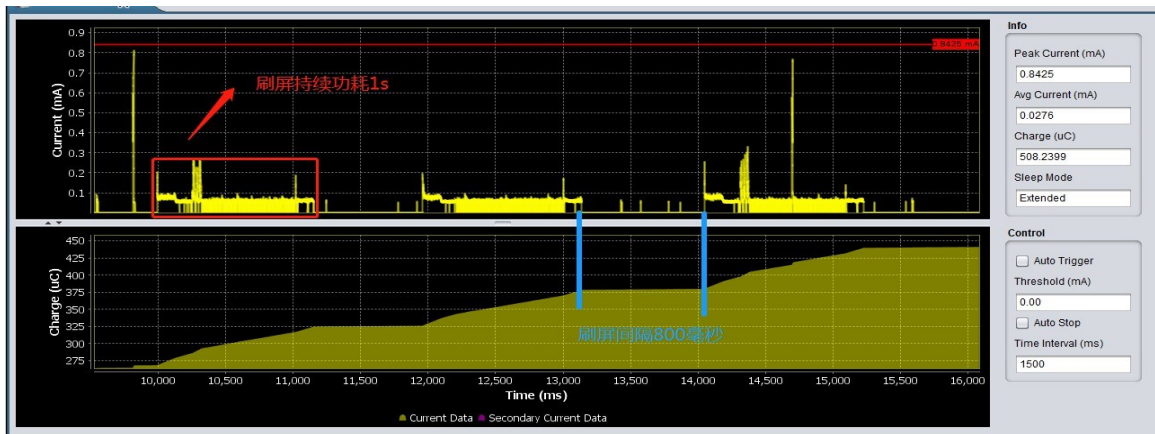

Average power consumption: 27.6 microamps

Analysis: The screen brushing interval is 800 milliseconds, and the power consumption of each screen brushing lasts for 1s

Test conclusion: The screen power consumption is $27.6 - 1.9 = 25.7$ mA

4.4 AC Timing Characteristic of The LCD

Please refer to the driver ST7305 IC specification

5. OPTICAL CHARACTERISTICS

Item	Symbol	Measuring Conditions		Min.	Typ.	Max.	Unit	Remark
Viewing Angle	θ	$\phi = 0^\circ$	25 °C	-	65	-	Deg	Note1
		$\phi = 180^\circ$	25 °C	-	65	-		
	θ	$\phi = 90^\circ$	25 °C	-	65	-		
		$\phi = 270^\circ$	25 °C	-	65	-		
Reflectance	T%	--	-	-	45.06	-	%	
Contrast ration	CR	--	25 °C	-	15	-	--	Note2
Response Time	Tr+Tf	$\theta = 0^\circ$ $\phi = 0^\circ$	25 °C	-	-	-	ms	Note3
Color of CIE Coordinate	White	X	25 °C	-	-	-	--	BM-7A
		Y	25 °C	-	-	-		
	Red	X	25 °C	-	-	-		
		Y	25 °C	-	-	-		
	Green	X	25 °C	-	-	-		
		Y	25 °C	-	-	-		
Blue	X	25 °C	-	-	-			
	Y	25 °C	-	-	-			

Note 1 Definition of Viewing Angle:

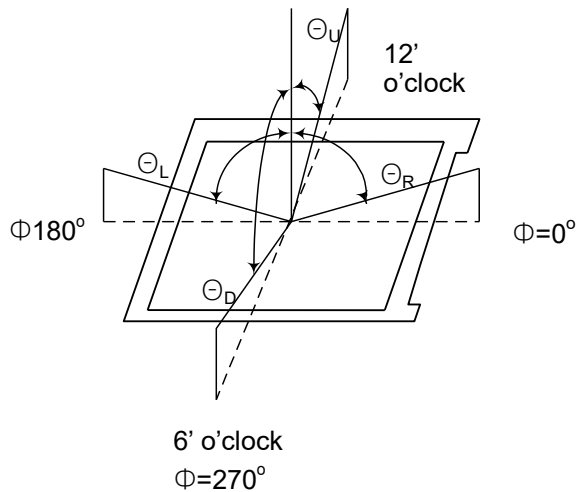

Note 2 Definition of Contrast Ratio (CR) :

measured at the center point of panel
Luminance with all pixels white

$$CR = \frac{\text{Luminance with all pixels white}}{\text{Luminance with all pixels black}}$$

Note 3 Definition of Response Time : Sum of Tr and Tf :

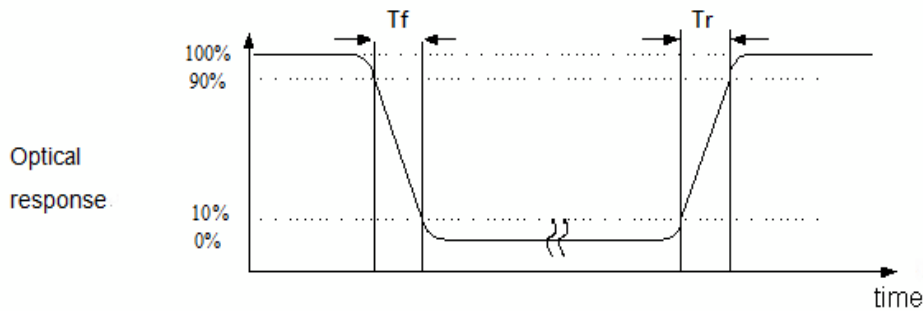

6. Reliability

Contents of Reliability Tests

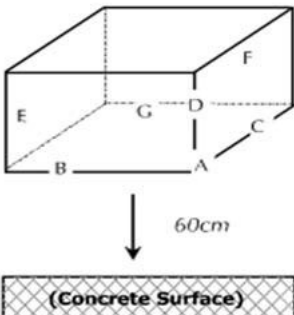
No.	Item	Conditions	Note
1	High Temperature Operation	70°C±2°C, 120 hrs	
2	Low Temperature Operation	-20°C±2°C, 120 hrs	
3	High Temperature Storage	80°C±2°C, 120 hrs	
4	Low Temperature Storage	-30°C±2°C, 120 hrs	
5	High Temperature /Humidity Operation	60°C±2°C, 90% RH, 120 hrs	
6	Temperature Cycling	-10°C→25°C→60°C→25°C→-10°C 30min 5min 30min 5min 30min 10 cycle.	
7	Vibration Test	Total fixed amplitude:1.5mm. Vibration Frequency:10~55Hz One cycle 60 seconds to 3 direction of X,Y,Z each 15 minutes.	
8	ESD Test	Air Discharge:Apple ±4KV with 5 times. Contact Discharge:Apple ±2KV with 5 times.	
9	Drop Test	To be measured after dropping from 60cm high on the concrete surface in packing state.  <i>Dropping method corner dropping:</i> <i>A corner: Once edge dropping.</i> <i>B, C, D edge: Once face dropping.</i> <i>E, F, G face: Once.</i>	

Note:

No charge on display and in operation under the following test condition.
Condition:Unless otherwise specified,tests will be conducted under the following condition.
Temperature:20°C±5°C.
Humidity:65±5%RH.
Tests will be not conducted under functioning state.

7. Package Specifications

Item		Quantity	
Module		TBD	per Primary Box
Holding Trays	(A)	15	per Primary Box
Total Trays	(B)	16	per Primary Box (Including 1 Empty Tray)
Primary Box	(C)	1~4	per Carton (4 as Major / Maximum)

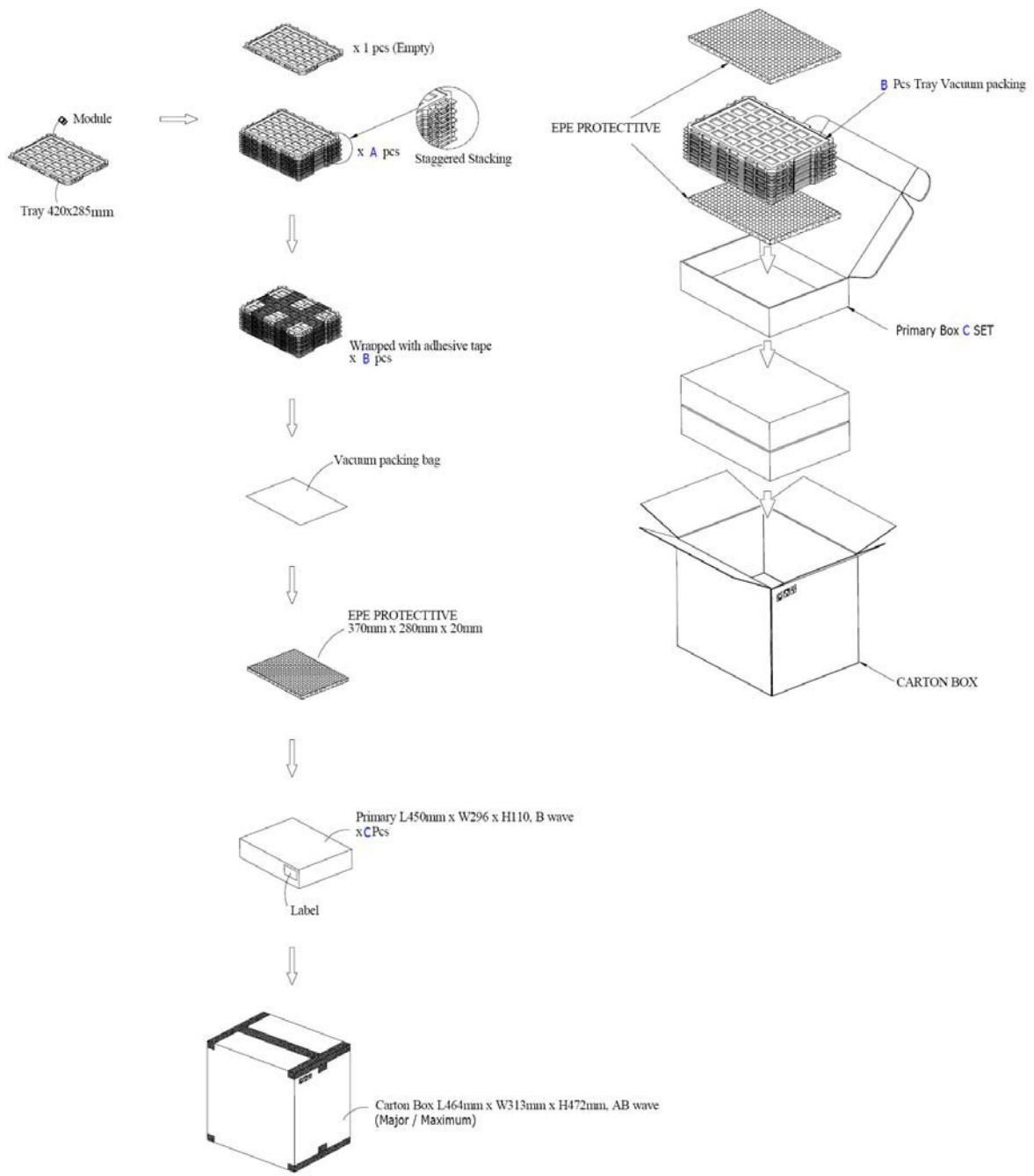

8. Precautions When Using These TFT Display Modules

8.1 Handling Precautions

- 1) Since the display panel is being made of glass, do not apply mechanical impacts such as dropping from a high position.
- 2) If the display panel is broken by some accident and the internal organic substance leaks out, be careful not to inhale nor lick the organic substance.
- 3) If pressure is applied to the display surface or its neighborhood of the TFT display module, the cell structure may be damaged and be careful not to apply pressure to these sections.
- 4) The polarizer covering the surface of the TFT display module is soft and easily scratched. Please be careful when handling the TFT display module.
- 5) When the surface of the polarizer of the TFT display module has soil, clean the surface. It takes advantage of by using following adhesion tape.
 - * Scotch Mending Tape No. 810 or an equivalentNever try to breathe upon the soiled surface nor wipe the surface using cloth containing solvent such as ethyl alcohol, since the surface of the polarizer will become cloudy. Also, pay attention that the following liquid and solvent may spoil the polarizer:
 - * Water
 - * Ketone
 - * Aromatic Solvents
- 6) Hold TFT display module very carefully when placing TFT display module into the system housing. Do not apply excessive stress or pressure to TFT display module. And, do not over bend the film with electrode pattern layouts. These stresses will influence the display performance. Also, secure sufficient rigidity for the outer cases.

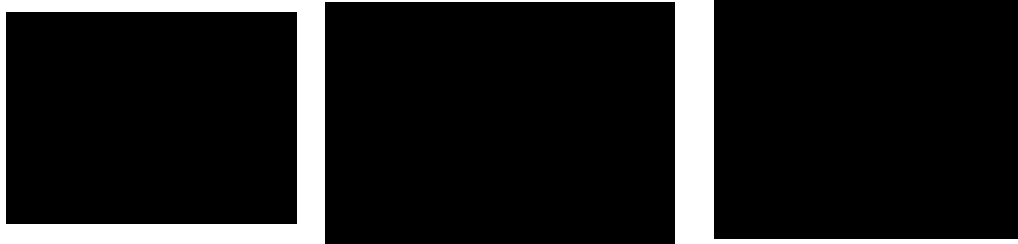

- 7) Do not apply stress to the driver IC and the surrounding molded sections.
- 8) Do not disassemble nor modify the TFT display module.
- 9) Do not apply input signals while the logic power is off.
- 10) Pay sufficient attention to the working environments when handling TFT display modules to prevent occurrence of element breakage accidents by static electricity.
 - * Be sure to make human body grounding when handling TFT display modules.
 - * Be sure to ground tools to use or assembly such as soldering irons.
 - * To suppress generation of static electricity, avoid carrying out assembly work under dry environments.
 - * Protective film is being applied to the surface of the display panel of the TFT display module. Be careful since static electricity may be generated when exfoliating the protective film.
- 11) Protection film is being applied to the surface of the display panel and removes the protection film before assembling it. At this time, if the TFT display module has been stored for a long period of time, residue adhesive material of the protection film may remain on the surface of the display panel after removed of the film. In such case, remove the residue material by the method introduced in the above Section 5).
- 12) If electric current is applied when the TFT display module is being dewed or when it is placed under high humidity environments, the electrodes may be corroded and be careful to avoid the above.

8.2 Storage Precautions

- 1) When storing TFT display modules, put them in static electricity preventive bags avoiding exposure to direct sun light nor to lights of fluorescent lamps. and, also, avoiding high temperature and high humidity environment or low temperature (less than 0°C) environments. (We recommend you to store these modules in the packaged state when they were shipped from Limito technology Inc.)
At that time, be careful not to let water drops adhere to the packages or bags nor let dewing occur with them.
- 2) If electric current is applied when water drops are adhering to the surface of the TFT display module, when the TFT display module is being dewed or when it is placed under high humidity environments, the electrodes may be corroded and be careful about the above.

8.3 Designing Precautions

- 1) The absolute maximum ratings are the ratings which cannot be exceeded for TFT display module, and if these values are exceeded, panel damage may be happen.
- 2) To prevent occurrence of malfunctioning by noise, pay attention to satisfy the V_{IL} and V_{IH} specifications and, at the same time, to make the signal line cable as short as possible.
- 3) We recommend you to install excess current preventive unit (fuses, etc.) to the power circuit (V_{DD}). (Recommend value: 0.5A)
- 4) Pay sufficient attention to avoid occurrence of mutual noise interference with the neighboring devices.
- 5) As for EMI, take necessary measures on the equipment side basically.
- 6) When fastening the TFT display module, fasten the external plastic housing section.
- 7) If power supply to the TFT display module is forcibly shut down by such errors as taking out the main battery while the TFT display panel is in operation, we cannot guarantee the quality of this OEL display module.
- 8) The electric potential to be connected to the rear face of the IC chip should be as follows:
 - * Connection (contact) to any other potential than the above may lead to rupture of the IC.

8.4 Precautions when disposing of the TFT display modules

- 1) Request the qualified companies to handle industrial wastes when disposing of the TFT display modules. Or, when burning them, be sure to observe the environmental and hygienic laws and regulations.

8.5 Other Precautions

- 1) When an TFT display module is operated for a long of time with fixed pattern may remain as an after image or slight contrast deviation may occur.
Nonetheless, if the operation is interrupted and left unused for a while, normal state can be restored. Also, there will be no problem in the reliability of the module.
- 2) To protect TFT display modules from performance drops by static electricity rapture, etc., do not touch the following sections whenever possible while handling the TFT display modules.
 - * Pins and electrodes
 - * Pattern layouts such as the FPC
- 3) With this TFT display module, the TFT driver is being exposed. Generally speaking, semiconductor elements change their characteristics when light is radiated according to the principle of the solar battery. Consequently, if this TFT driver is exposed to light, malfunctioning may occur.
 - * Design the product and installation method so that the TFT driver may be shielded from light in actual usage.
 - * Design the product and installation method so that the TFT driver may be shielded from light during the inspection processes.
- 4) Although this TFT display module stores the operation state data by the commands and the indication data, when excessive external noise, etc. enters into the module, the internal status may be changed. It therefore is necessary to take appropriate measures to suppress noise generation or to protect from influences of noise on the system design.
- 5) We recommend you to construct its software to make periodical refreshment of the operation statuses (re-setting of the commands and re-transference of the display data) to cope with catastrophic noise.

9. Warranty:

The warranty period shall last twelve (12) months from the date of delivery. Buyer shall be completed to assemble all the processes within the effective twelve (12) months. Good Display shall be liable for replacing any products which contain defective material or process which do not conform to the product specification, applicable drawings and specifications during the warranty period. All products must be preserved, handled and appearance to permit efficient handling during warranty period. The warranty coverage would be exclusive while the returned goods are out of the terms above.

10. Notice:

No part of this material may be reproduces or duplicated in any form or by any means without the written permission of Good Display. we would reserve the right to make changes to this material without notice. . does not assume any liability of any kind arising out of any inaccuracies contained in this material or due to its application or use in any product or circuit and, further, there is no representation that this material is applicable to products requiring high level reliability, such as, medical products. Moreover, no license to any intellectual property rights is granted by implication or otherwise, and there is no representation or warranty that anything made in accordance with this material will be free from any patent or copyright infringement of a third party. This material or portions thereof may contain technology or the subject relating to strategic products under the control of Foreign Exchange and Foreign Trade Law of Taiwan and may require an export license from the Ministry of International Trade and Industry or other approval from another government agency.