



Your Solution for Frequency Control Products



OSCILLATORS
PXO / XO



Mit 50 Jahren Erfahrung in der Quarz Branche ist **GEYER electronic** ein weltweit bekannter Hersteller von hochwertigen Schwingquarzen und Oszillatoren.

Der vorliegende Katalog bietet einen Überblick über das **GEYER Oszillatoren** (PXO/XO) Bauteilesortiment. Weitere Bauformen und Sondertypen sind auf Anfrage lieferbar.

Für Neuentwicklungen und Freigabeprozesse stellt **GEYER electronic** kurzfristig geeignete Musterbauteile zur Verfügung. Darüber hinaus steht ein kompetentes Team von Design- und Entwicklungsingenieuren ganz im Dienste des Kunden und unterstützt bei der Auslegung von Schaltungen. Im **GEYER electronic** Design- und Testzentrum sind verschiedenste Messungen und Analysen, auch in der Klimasimulation, möglich.

With 50 years' experience in the frequency control marketplace, **GEYER electronic** is a world-renown manufacturer of quality quartz crystals and oscillators.

The catalog in front of you offers an overview of the **GEYER** component product range of **Clock Oscillators** (PXO/XO). A variety of further packages and special types is available on request.

GEYER is pleased to provide suitable samples at short notice for new developments and approval processes. In addition, a competent team of design and development engineers committed to customers is available to provide support for the design of circuits. In the **GEYER electronic** Design and Test Center, a wide variety of measurements and analyses can be carried out, including in our climactic simulation test chamber.









Be sure with Quartz Crystals from GEYER



This catalogue replaces all former catalogues. All specifications represent the latest technical information and are subject to change without notice. For current update please refer to www.geyer-electronic.com.

All rights are reserved by GEYER electronic. No part of this publication may be reproduced for commercial purpose without permission from GEYER electronic. All deliveries are according to our terms of trade. See page 16.

Contents

	Size mm	Frequency	Page	
			04	
GEYER Service				
Clock Oscillators SMD				
	KXO-56 SSO	3.2 2.5 1.0	10 ~ 26 MHz	05
	KXO-V94	3.2 2.5 1.0	1.25 ~ 54 MHz	06
	KXO-V95	7.0 5.0 1.7	1.544 ~ 77.760 MHz	07
	KXO-V96	7.0 5.0 1.7	1.544 ~ 77.760 MHz	08
	KXO-V99	2.0 1.6 0.7	13 ~ 52 MHz	09
	KXO-V97	2.5 2.0 0.7	12 ~ 26 MHz	10
	KXO-97	2.5 2.0 0.7	13 ~ 54 MHz	11
	KXO-200, KXO-400	20.8 13.2 5.08	0.5 ~ 100 MHz	12 - 13
	KXO-210, KXO-410	13.2 13.2 6.0	0.5 ~ 100 MHz	12 - 13
Technical Introduction				
			14	
Terms of Trade			15	
Contact Information			16	

For other pdf-Crystal catalogues please refer to our website:
<http://www.geyer-electronic.de/Service.48+B6Jkw9MQ...0.html>

- GEYER Overview Crystal Products
- GEYER Tuning Fork Crystals
- GEYER Oscillators, VCXO TCXO VCTCXO LVDS PECL
- GEYER VCO and PLL Modules
- GEYER SAW Filter



www.geyer-electronic.com/service

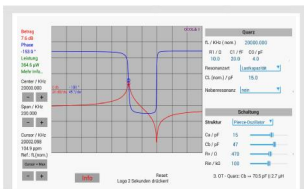

Design und Testcenter

Auswahl von Bauteilen
Schaltungsbegutachtung
Messungen und Analysen von Baugruppen

Wir bieten einen weltweit außergewöhnlichen Service:

- Ausführliche Beratung
- Validierung Ihrer Schaltung
- Ausgemessene Muster für Vorserien und Prototypen
- Abgestimmte Spezifikationen und Baugrößen
- 3D Modelle unserer Bauteile zur Erleichterung des Design-in
- Kostenlose Simulations - App
- Test der fertigen Baugruppe auf verschiedenste Parameter

Die Vorteile für Sie:

- Vermeidung von Unsicherheiten bei der Bauteileauswahl oder Spezifikation
- Verkürzte Entwicklungsdauer
- Erhöhte Betriebssicherheit in der Serie
- Kostentoptimierte Bauteileauswahl
- Optimale Lebenserwartung in der Serie

Sie erhalten:

- Ausführliche Beratung zum Schaltungsdesign neuer Schaltungen

Unter den Gesichtspunkten von:

- Frequenzgenauigkeit von unterschiedlichen Versorgungsspannungen
- Frequenzgenauigkeit über den Arbeitstemperaturbereich
- Anschwingverhalten bei verschiedenen Temperaturen
- Anschwingsicherheit
- Stromverbrauch
- Layout Optimierung
- Auswahl kostengünstiger Bauteile

Part selection Evaluation of Circuit Design Measurements and Analysis of PCBs

We offer your Design Engineers an exceptional worldwide service:

- Comprehensive consulting
- Validation of your design
- Our own Design and Test center
- Selected samples for prototypes and pilot series
- Matched specifications and design sizes
- 3D models of our components for easy design-in
- Free Geyer App-Y-Quartz with analyzing tool
- Testing of boards on selected parameters

As a customer you can expect the following benefits:

- Prevention from incorrect decisions in component selection or specification
- Shorter development time
- Enhanced reliability of operation in production run
- Cost-optimized component selection
- Optimum design life in production run

You get:

- Comprehensive advice in design of new circuits

With regard to:

- Frequency deviation at different supply voltages
- Frequency deviation at different temperatures
- Start-up at different temperatures
- Start allowance
- Current consumption
- Layout optimizing
- Selection of economic components



SSO Spread Spectrum Oscillator

SMD-version

model	KXO-56				
frequency range	1,0 ~ 134,0 MHz				
frequency stability max.	± 50 ppm				
operating temperature	-40° ~ +85°C				
storage temperature	-40° ~ +85°C				
symmetry (duty)	40% ~ 60%				
center spread ±0,5% ~ ±2%	±0,5% = Typ C05	±0,75% = Typ C07	±1,0% = Typ C10	±1,5% = Typ C15	±2,0% = Typ C20
down spread -0,5% ~ -4%	-0,5% = Typ D05	-1,0% = Typ D10	-1,5% = Typ D15	-2,0% = Typ D20	-3,0% = Typ D30 -4,0% = Typ D40
output rise & fall time	10 ns max.				
high output voltage	80% V _{DD} min.				
low output voltage	20% V _{DD} max.				
input voltage V _{DD}	+3,3V ±10%				
Input current max.	20 mA				
supply voltage	-0,5V ~ +4V DC				
output load	CMOS 15 pF				
output enable voltage	80% V _{DD} min.				
output disable voltage	20% V _{DD} max.				
oscillation start up time	10 ms max.				
period jitter	100 ps max.				
contents of reel	1000 pcs.				
part no.	12.xxxxx				



Dimensions (mm):

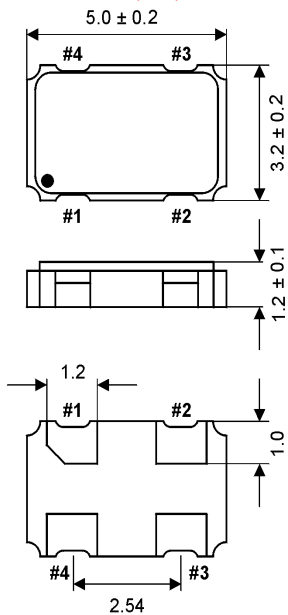

Output waveform:

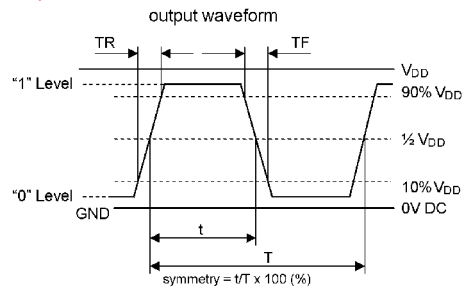

Reflow soldering condition:

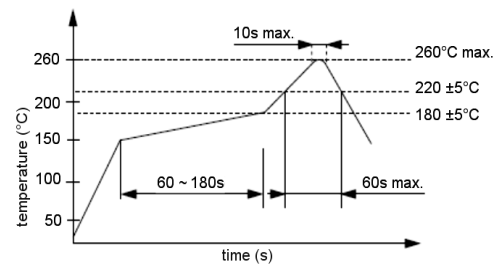

Test circuit:

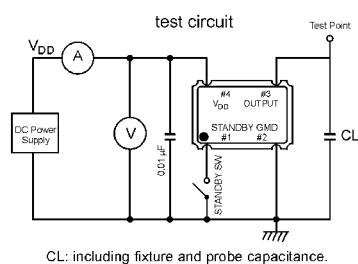

Center Spread:

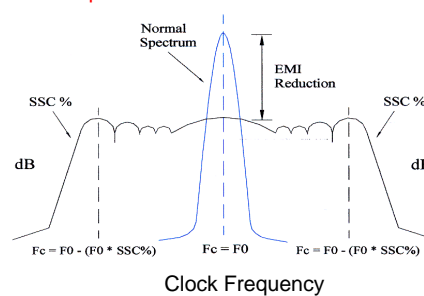

Suggested soldering pad:

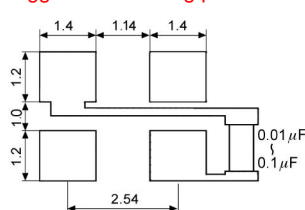

Down Spread:

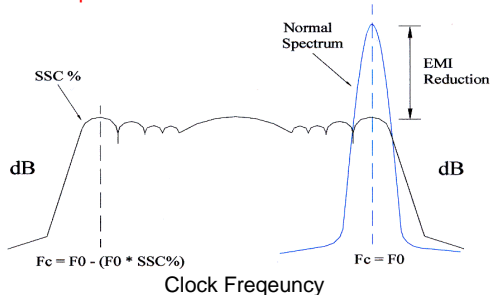

PIN	Connection
1	"L" (OV) "H" or OPEN
2	GND
3	Z OUTPUT
4	V _{DD}

Z= High Impedance



Clock Oscillator SMD-version

+1.8V / +2.5V / +2.8V / +3.0V / +3.3V

model	KXO-V94			
frequency range	1.0 ~ 80.0 MHz			
frequency stability at -20° ~ +70°C	± 50 ppm			
at -40° ~ +85°C	± 100 ppm			
operating temperature	standard -20° ~ +70°C available -40° ~ +85°C (=KXO-V94T)			
storage temperature	-55° ~ +100°C			
symmetry	45% ~ 55% at 50% V _{DD} level			
rise & fall time max.	6 ns (10% V _{DD} ~ 90% V _{DD} level)/V _{DD} = +1.8V 5 ns (10% V _{DD} ~ 90% V _{DD} level)/V _{DD} +1.8V, +2.5V +2.8V +3.0V +3.3V			
"0" level max.	VOL: 10% V _{DD}			
"1" level min.	VOH: 90% V _{DD}			
input voltage V _{DD}	+1.8V, +2.5V, +2.8V, +3.0V, +3.3V DC ±5%			
tri-state control voltage (Pin#1)	VIH: V _{DD} x 0,7 min. VIL: V _{DD} x 0,3 max.			
supply voltage	-0.5V ~ +4.0V			
input current max.		+1.8V	+2.5V/+2.8V	+3.0V/+3.3V
	0.75 ~ 19.9 MHz	2.5mA	4.5mA	6.0mA
	20.0 ~ 39.9 MHz	3.0mA	5.5mA	7.0mA
	40.0 ~ 49.9 MHz	3.5mA	6.5mA	8.0mA
	50.0 ~ 80.0 MHz	6.5mA	7.0mA	9.0mA
output load max.	15pF (CMOS)			
start up time max.	10 ms			
disable delay time max.	150 ns			
enable delay time max.	10 ms			
stand by current max.	10 µA (Pin #1=VIL)			
contents of reel	1000 pcs.			
part no.	12.xxxxx			

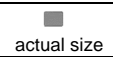

Dimensions (mm):

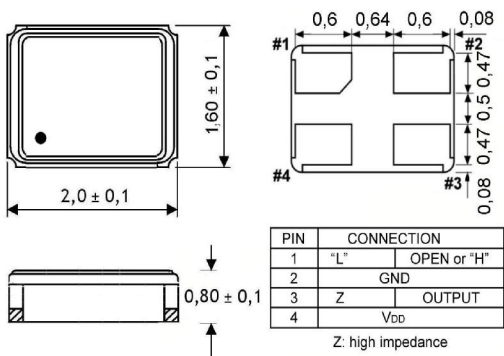

Test circuit:

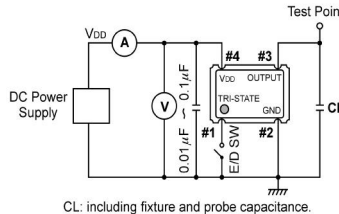

Reflow soldering condition:

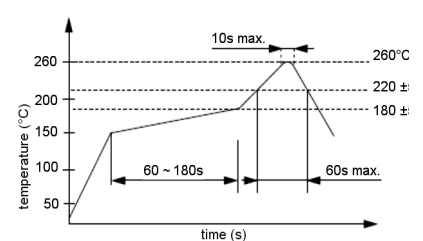

Suggested soldering pad:

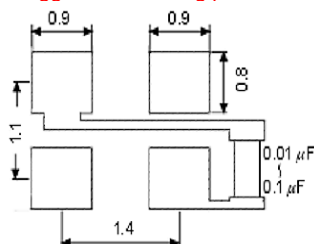

Output waveform:

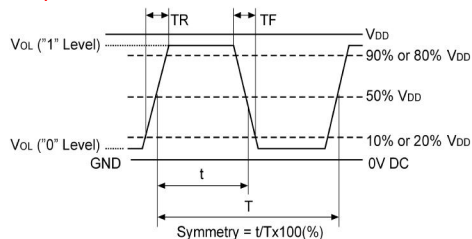

Tape specification:

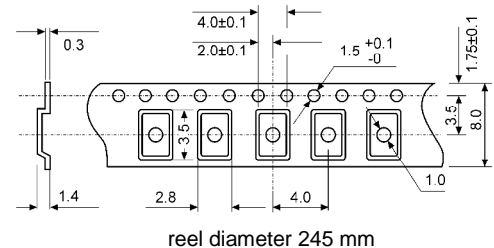



Clock Oscillator SMD-version

+1.8V / +2.5V / +2.8V / +3.0V / +3.3V

model	KXO-V95			
frequency range	1.0 ~ 70.0 MHz			
frequency stability				
at -20° ~ + 70°C	± 50 ppm			
at -40° ~ + 85°C	± 100 ppm			
at -40° ~ +105°C	± 120 ppm			
operating temperature	standard -20° ~ + 70°C			
	available -40° ~ + 85°C (=KXO-V95T)			
	available -40° ~ +105°C (=KXO-V95E)			
storage temperature	-40° ~ +85°C			
symmetry	40% ~ 60% at 50% V _{DD} level			
rise & fall time max.	10 ns (10% V _{DD} ~ 90% V _{DD} level)			
"0" level max.	VOL: 10% V _{DD}			
"1" level min.	VOH: 90% V _{DD}			
input voltage V _{DD}	+1.8 ~ +3.3V ±5%			
tri-state control voltage (Pin#1)	VIH: V _{DD} x 0,7 min. VIL: V _{DD} x 0,3 max.			
supply voltage	-0.5V ~ +7.0V			
input current		+1.8V	+2.5V	+3.0V/+3.3V
	1.0 ~ 20.0MHz	3.5 mA typ., 6.0 mA max.	4.0 mA typ., 6.0 mA max.	4.0 mA typ., 6.0 mA max.
	20.1 ~ 50.0MHz	4.5 mA typ., 6.0 mA max.	4.0 mA typ.11.0 mA max.	6.0 mA typ 11.0 mA max.
	50.1 ~ 70.0MHz	6.0 mA typ.11.0 mA max.	6.0 mA typ.11.0 mA max.	9.0 mA typ.16.0 mA max.
output load max.	15pF (CMOS)			
start up time max.	10 ms			
disable delay time max.	150 ns			
enable delay time max.	10 ms			
stand by current max.	50 µA (Pin #1=VIL)			
jitter		deterministic jitter	5ps max.	norm 1-sigma
		random jitter	7ps max.	peak to peak
				7ps max.
				40ps max.
AECQ 200	available			
contents of reel	1000 pcs.			
part no.	12.xxxxx			



Dimensions (mm):

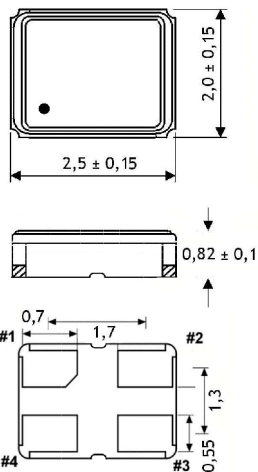

PIN	CONNECTION
1	"L" OPEN or "H"
2	GND
3	OUTPUT
4	V _{DD}

Z: high impedance

Output waveform:

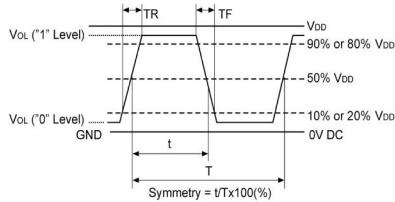

Test circuit:

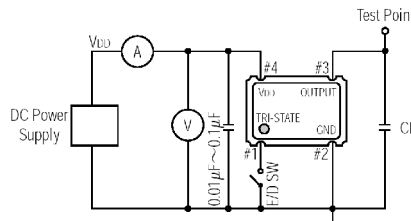

Suggested soldering pad:

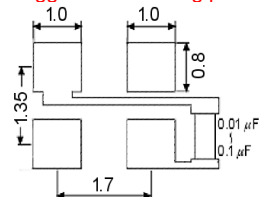

Reflow soldering condition:

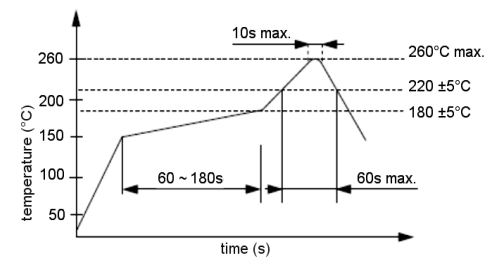

Tape specification:

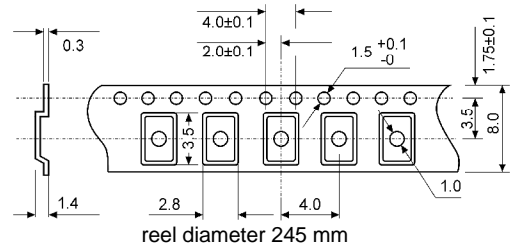



Clock Oscillator SMD-version

1.8V / +2.5V / +2.8V / +3.0V / +3.3V

model	KXO-V96			
frequency range	1.0 ~ 133.0 MHz			
frequency stability	at -20° ~ + 70°C ± 50 ppm at -40° ~ + 85°C ± 100 ppm at -40° ~ +105°C ± 120 ppm			
operating temperature	standard -20° ~ + 70°C available -40° ~ + 85°C (=KXO-V96T) available -40° ~ +105°C (=KXO-V96E)			
storage temperature	-50° ~ +125°C			
symmetry	40% ~ 60% at 50% V _{DD} level			
rise & fall time max.	5 ns (10% V _{DD} ~ 90% V _{DD} level)			
"0" level max.	VOL: 10% V _{DD}			
"1" level min.	VOH: 90% V _{DD}			
input voltage V _{DD}	+1.8 ~ +3.3V ±5%			
stand-by control voltage (pin#1)	VIH(min): 70% V _{DD} VIL(max): 30%V _{DD} *			
supply voltage	-0.5V ~ +7.0V			
input current		+1.8V	+2.5V	+3.0V/+3.3V
	1.0 ~ 20.0MHz	3.5 mA typ., 6.0 mA max.	4.0 mA typ., 6.0 mA max.	4.0 mA typ., 6.0 mA max.
	20.1 ~ 50.0MHz	4.5 mA typ., 6.0 mA max.	4.0 mA typ., 11.0 mA max.	6.0 mA typ., 11.0 mA max.
	50.1 ~ 80.0MHz	6.0 mA typ., 11.0 mA max.	6.0 mA typ., 11.0 mA max.	9.0 mA typ., 16.0 mA max.
	80.1 ~ 133.0MHz	15 mA typ., 20 mA max.	20 mA typ., 40 mA max.	20 mA typ., 40 mA max.
output load max.	15pF (HCMOS)			
start up time max.	10 ms			
disable delay time max.	150 ns			
enable delay time max.	10 ms			
stand by current max.	50 µA (Pin #1=VIL)			
jitter	deterministic jitter	5ps max.	norm 1-sigma	7ps max.
	random jitter	7ps max.	peak to peak	40ps max.
AECQ 200	available			
contents of reel	1000 pcs.			
part no.	12.xxxxx			



* Internal crystal oscillation to be halted (pin#1=VIL)

Dimensions (mm):

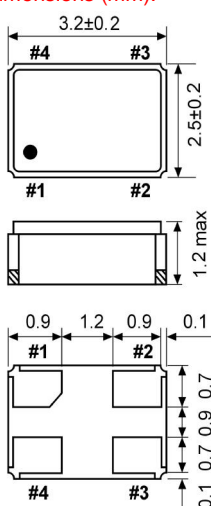

PIN	CONNECTION
1	"L" OPEN or "H"
2	GND
3	Z OUTPUT
4	V _{DD}

Z: high impedance

Test circuit:

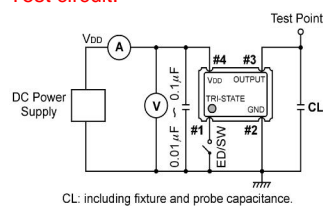

CL: including fixture and probe capacitance.

Suggested soldering pad:

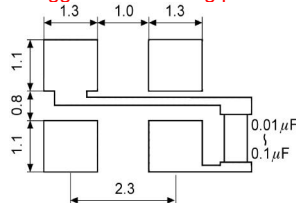

Reflow soldering condition:

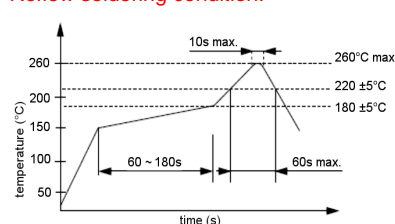

Output waveform:

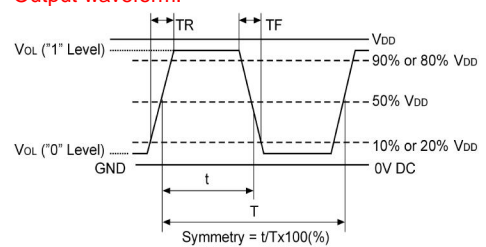

Tape specification:

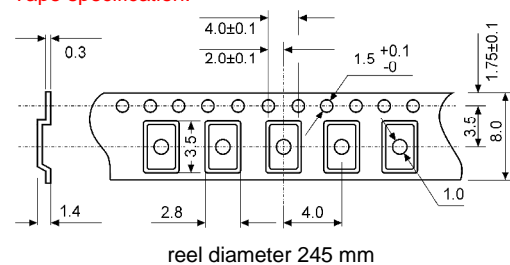



Clock Oscillator SMD-version

+1.8V / +2.5V / +3.0V / +3.3V

model	KXO-V99			
frequency range	1.0 ~ 200.0 MHz			
frequency stability				
at -20° ~ +70°C	± 50 ppm			
at -40° ~ +85°C	± 100 ppm			
at -40° ~ +105°C	± 120 ppm			
operating temperature	standard -20° ~ +70°C available -40° ~ +85°C (=KXO-V99T) available -40° ~ +105°C (=KXO-V99E)			
storage temperature	-55° ~ +125°C			
symmetry				
at 1,0 ~ 70,0 MHz	45%/55% ± 10% at ½ V _{DD} level			
at 70,1 ~ 200,0 MHz	40%/60% ± 10% at ½ V _{DD} level			
rise & fall time max.	4 ns			
"0" level max.	V _{DD} x 0,1V			
"1" level min.	V _{DD} x 0,9 V			
input voltage V _{DD}	standard + 3.3V ± 5% available +1.8V ± 5%/ +2.5V / +3.0V each type ±5%			
input current		+1.8V	+2.5V	+3.0V/+3.3V
	1.0 ~ 20.0MHz	3.5 mA typ., 6.0 mA max.	4.0 mA typ., 6.0 mA max.	4.0 mA typ., 6.0 mA max.
	20.1 ~ 50.0MHz	4.5 mA typ., 6.0 mA max.	4.0 mA typ., 11.0 mA max.	6.0 mA typ., 11.0 mA max.
	50.1 ~ 80.0MHz	6.0 mA typ., 11.0 mA max.	6.0 mA typ., 11.0 mA max.	9.0 mA typ., 16.0 mA max.
	80.1 ~ 125.0MHz	30 mA typ., 50 mA max.	30 mA typ., 50 mA max.	30 mA typ., 50 mA max.
	125.1 ~ 165.0MHz	50 mA typ., 65 mA max.	50 mA typ., 65 mA max.	50 mA typ., 65 mA max.
	165.1 ~ 200.0MHz	60 mA typ., 75 mA max.	60 mA typ., 75 mA max.	60 mA typ., 75 mA max.
output load	15pF			
start up time max.	10 ms			
tristate function	yes			
disable delay time	100 ns max.			
enable delay time	4 ms max.			
stand by current	10 µA max.			
random jitter	7pS max.			
peak to peak jitter	40pS max.			
contents of reel	1000 pcs.			
part no.	12.xxxxx			



Dimensions (mm):

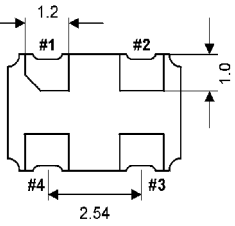
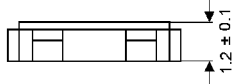
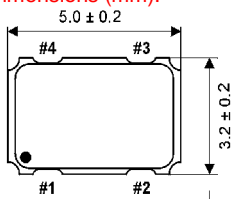

PIN	Connection
1	"L" (OV) "H" or OPEN
2	GND
3	Z OUTPUT
4	V _{DD}

Test circuit:

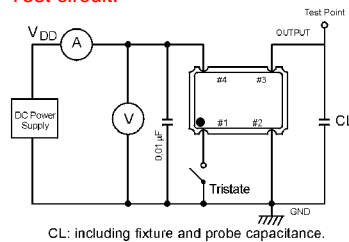

Suggested soldering pad:

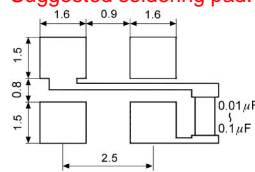

Reflow soldering condition:

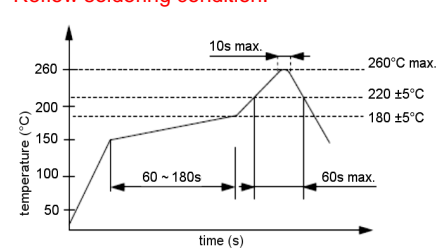

Output waveform:

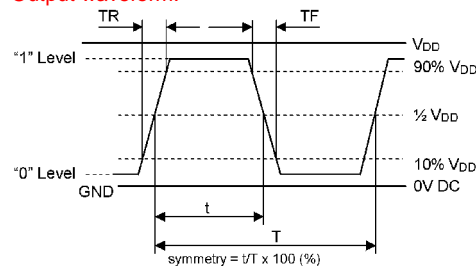

Tape specification:

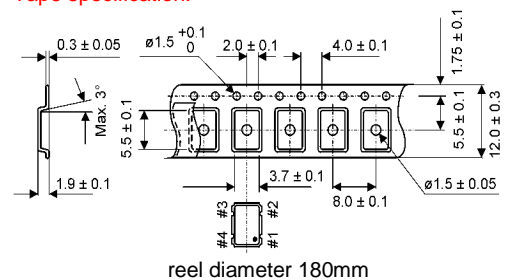



Clock Oscillator SMD-version

+1.8V / +2.5V / +3.0V / +3.3V

model	KXO-V97		
frequency range	1.0 ~ 50.0 MHz	50.1 ~ 80.0 MHz	80.1 ~ 160.0 MHz
frequency stability at -20° ~ + 70°C at -40° ~ + 85°C at -40° ~ +105°C	± 50 ppm ± 100 ppm ± 120 ppm		
operating temperature	standard -20° ~ + 70°C available -40° ~ + 85°C (=KXO-V97T) available -40° ~ +105°C (=KXO-V97E)		
storage temperature	-40° ~ +85°C		
symmetry	50% ± 10% at ½ V _{DD} level		
rise & fall time max.	6 ns	5 ns	2,5 ns
"0" level max.	+ 0.4V		
"1" level min.	V _{DD} -0.5V		
input voltage V _{DD}	standard + 3.3V ± 10% available +1.8V ± 5%/ +2.5V ± 5%/ +3.0V ± 10%		
input current	3.5 ~ 6.0 mA typ. 6.0 ~ 11.0 mA max.	6.0 ~ 9.0 mA typ. 11.0 ~ 16.0 mA max.	30.0 mA typ., 40.0 mA max.
output load	1.0 ~ 33.0 MHz 30 pF 33.1 ~ 75.0 MHz 30 pF 75.1 ~ 150.0 MHz 15 pF		
start up time max.	10 ms	10 ms	4 ms
tristate function	yes		
disable delay time	100 ns max.		
enable delay time	4 ms max.		
random jitter	7ps max.		
peak to peak jitter	40ps max.		
contents of reel	1000 pcs.		
part no.	12.xxxxx		



Dimensions (mm):

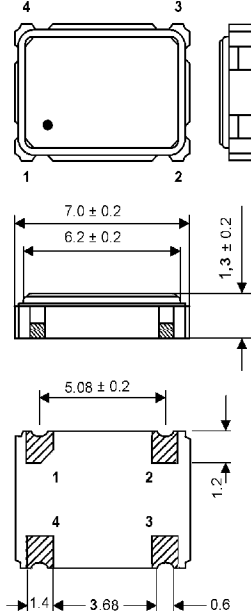

PIN	CONNECTION
1	"L" (OV) "H" or OPEN
2	GND
3	OUTPUT
4	V _{DD}

Z: high impedance

Output waveform:

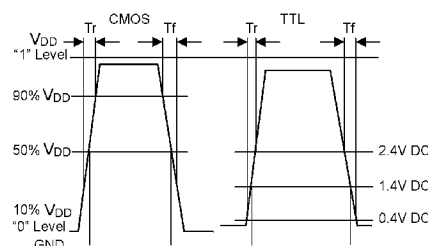

Test circuit:

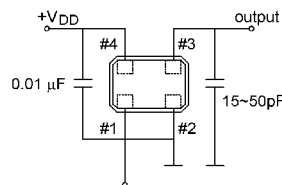

Suggested soldering pad:

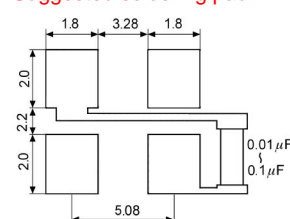

Reflow soldering condition:

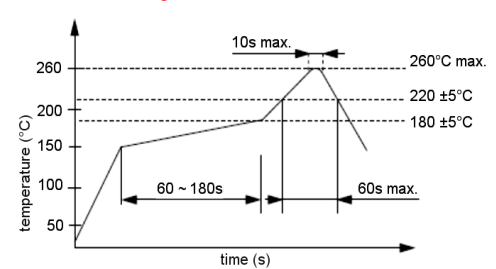

Tape specification:

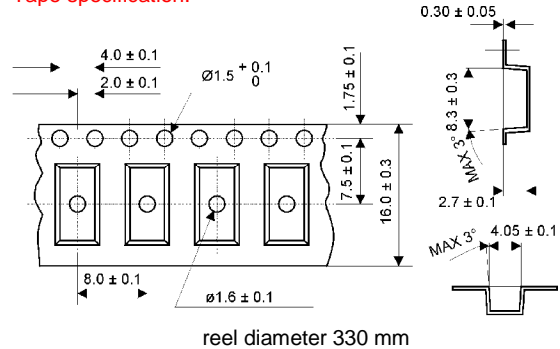

OSCILLATOR – KXO-V97



Clock Oscillator SMD-version

+5V

model	KXO-97		
frequency range	1.0 ~ 50.0 MHz	50,1 ~ 80,0 MHz	80,1 ~ 100,0 MHz
frequency stability at -20° ~ + 70°C at -40° ~ + 85°C at -40° ~ +105°C	± 50 ppm ± 100 ppm ± 120 ppm		
operating temperature	standard -20° ~ + 70°C available -40° ~ + 85°C (=KXO-97T) available -40° ~ +105°C (=KXO-97E)		
storage temperature	-40° ~ +85°C		
symmetry	50% \pm 10% at 1,4V DC level or $\frac{1}{2}$ V _{DD} level		
rise & fall time max.	TTL: 6 ns / CMOS: 10 ns		5 ns
"0" level max.	+ 0.4V (TTL) / + 0.5V (CMOS)		
"1" level min.	+2.4V (TTL) / V _{DD} -0.5V (CMOS)		
input voltage V _{DD}	+ 5V DC \pm 10%		
input current	1.0 ~ 9.9 MHz 10 mA max. 10.0 ~ 19.9 MHz 15 mA max. 20.0 ~ 29.9 MHz 25 mA max. 30.0 ~ 50.0 MHz 35 mA max.	40 mA typ., 50 mA max.	60 mA typ, 80 mA max.
output load	1.0 ~ 33.0 MHz 10 TTL gates 50 pF 33.1 ~ 75.0 MHz 5 TTL gates 30 pF 75.1 ~ 100.0 MHz 5 TTL gates 15 pF		
start up time max.	10 ms		
tristate function	yes		
disable delay time	100 ns max.		
enable delay time	4 ms max.		
random jitter	7ps max.		
peak to peak jitter	40ps max.		
contents of reel	1000 pcs.		
part no.	12.xxxxx		



Dimensions (mm):

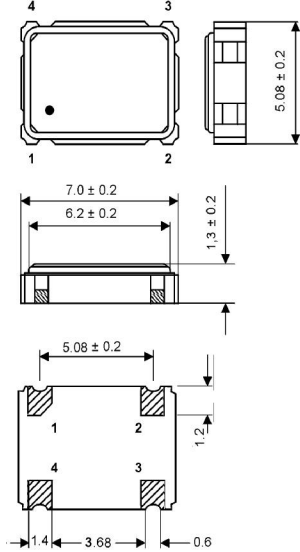

PIN	CONNECTION
1	"L" (OV) "H" or OPEN
2	GND
3	Z OUTPUT
4	V _{DD}

Z: high impedance

Output waveform:

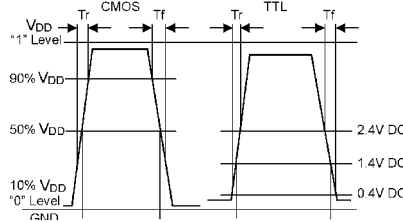

Test circuit:

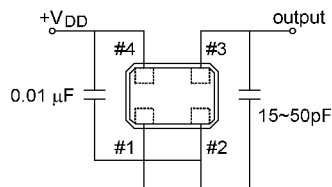

Suggested soldering pad:

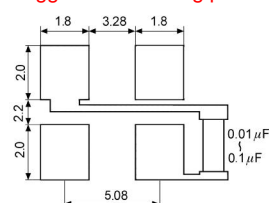

Reflow soldering condition:

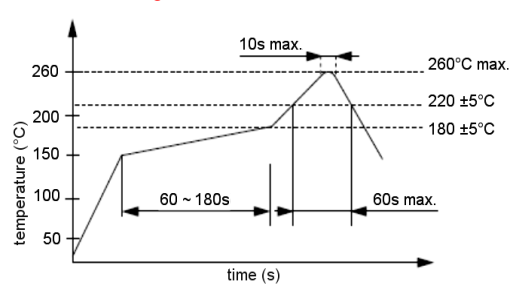

Tape specifications:

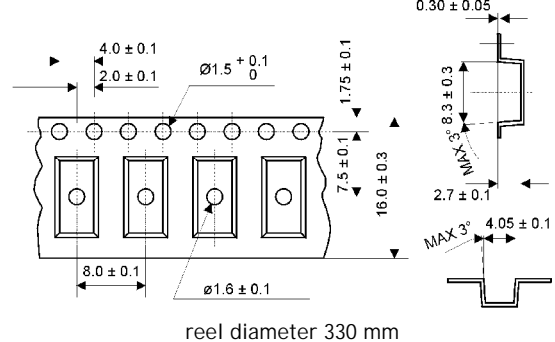

OSCILLATOR – KXO-97



Clock Oscillator

TTL / HCMOS, TRI-STATE

item	TTL & HCMOS		Tri-State																
	model	KXO-200	KXO-210	KXO-400	KXO-410														
package	DIL 14	DIL 8	DIL 14	DIL 8															
frequency range	0.5 ~ 100 MHz *		0.5 ~ 100 MHz																
frequency stability	standard ± 100 ppm available ± 25 ppm ~ ± 100 ppm																		
storage temperature range	-55°C ~ +125°C																		
operating temperature range	standard -20°C ~ +70°C available -40°C ~ +85°C (=KXO-205/215) (=KXO-405/415)																		
symmetry	standard 60/40% (+ 1/2 V _{DD}) available 55/45%		standard 60/40% (+ 1/2 V _{DD}) available 55/45%																
rise and fall time max.	10 ns 0.5 ~ 25 MHz 6 ns 25.1 ~ 70 MHz 4 ns 70.1 ~ 100 MHz		10 ns 0.5 ~ 25 MHz 6 ns 25.1 ~ 70 MHz 4 ns 70.1 ~ 100 MHz																
"0" level max.	+0.5V (10%V _{DD})		+0.5V (10%V _{DD})																
"1" level min.	+4.5V (90%V _{DD})		+4.5V (90%V _{DD})																
input voltage	+5.0V DC ± 10%		+5.0V DC ± 10%																
input current max.	20 mA 0.5 ~ 20 MHz 40 mA 20.1 ~ 70 MHz 60 mA 70.1 ~ 100 MHz		20 mA 0.5 ~ 20 MHz 40 mA 20.1 ~ 70 MHz 60 mA 70.1 ~ 100 MHz																
output load	1 - 8 TTL or CL = 50pF (TYP)		1 - 8TTL or CL = 50pF (TYP)																
dimension	fig.1	fig.2	fig.1	fig.2															
logic family	TTL & HCMOS compatible		TTL or HCMOS compatible																
test circuit	fig. 3. 4		fig. 3. 4																
pin connection	# 1 (#1): NC # 7 (#4): CASE GND # 8 (#5): OUTPUT #14 (#8): +V _{DD}		<table border="1"> <thead> <tr> <th>PIN</th> <th colspan="2">CONNECTION</th> </tr> </thead> <tbody> <tr> <td>#1 (#1)</td> <td>.L*(OV)</td> <td>.H*(+5V) or OPEN</td> </tr> <tr> <td>#7 (#4)</td> <td colspan="2">GND</td> </tr> <tr> <td>#8 (#5)</td> <td>Z</td> <td>OUTPUT</td> </tr> <tr> <td>#14 (#8)</td> <td colspan="2">V_{DD}</td> </tr> </tbody> </table>		PIN	CONNECTION		#1 (#1)	.L*(OV)	.H*(+5V) or OPEN	#7 (#4)	GND		#8 (#5)	Z	OUTPUT	#14 (#8)	V _{DD}	
PIN	CONNECTION																		
#1 (#1)	.L*(OV)	.H*(+5V) or OPEN																	
#7 (#4)	GND																		
#8 (#5)	Z	OUTPUT																	
#14 (#8)	V _{DD}																		
packing unit	25 pcs.	40 pcs.	25 pcs.	40 pcs.															
order no.	12.xxxxx	12.xxxxx	12.xxxxx	12.xxxxx															

* > 100,0 MHz on request

Z: high impedance

Enable/Disable Phase Delay Time 100 ns max.

Technical explanation of crystal oscillators

XO	Crystal oscillator	Typical supply voltages: 1.8/2.5/3.0/3.3 or 5 Volt. Typical output levels: clipped sine/TTL/HCMOS. The same temperature characteristics as a corresponding crystal.
VCXO	Voltage controlled oscillator	Typical supply voltages and output levels as above. Can be pulled up or down over a specified frequency range by applying a control voltage to a control pin. Note: This pin must be connected to a specified voltage. Grounding, pulling to V_{DD} or leave open (NC) will seriously degrade the properties of the oscillator. If the pullability is not needed, better choose a XO.
TCXO	Temperature compensated oscillator	Typical supply voltages and output levels as above. About one order of magnitude better accuracy over temperature than XOs.
VCTCXO	Voltage controlled temperature compensated oscillator	A combination of the oscillator types mentioned afore. The same note also applies here.
SSO	Spread spectrum oscillator	The output frequency varies continuously around the desired frequency to avoid discrete signal peaks in the output noise spectrum. Typical center sweeps are +/-0.5% to +/-2.0%, typical down sweeps are -0.5% to -4%. Typical supply voltage is 3.3V. Typical output signal level is HCMOS.
LVDS	Low-voltage differential signal oscillator	High speed oscillator with differential output (ANSI/TIA/EIA-644A). Output swing +/-350mV. Typical supply voltage 2.5V/3.3V. Low power consumption.
(LV)PECL	Low-Voltage Positive-Emitter-Coupled Logic	High speed oscillator with differential output. Output swing +/-800mV. Typical supply voltage 2.5V/3.3V. Medium to high power consumption-

GEYER worldwide



www.geyer-electronic.com

GEYER ELECTRONIC . HQ GERMANY
Lochhamer Schlag 5 D-82166 Gräfelfing / München
Tel: +49 89 546868-0 Fax: +49 89 546868-91 e-mail: info@geyer-electronic.de

GEYER ELECTRONIC UK office
Romsey/Hampshire
Tel: +44 1794 329341 • e-mail: sales@geyer-electronic.co.uk

GEYER ELECTRONIC France Office
Brehal / Manche
Tel. +33 950 32 4987 Cellphone: +33 781 51 6993 e-mail: poullain@geyer-france.fr

GEYER ELECTRONIC HUNGARY Kft.
Budapest
Tel: +36 70 413 84 32 Fax: +36 7090 83 000
e-mail: kollmann@geyer-electronic.hu e-mail: machata@geyer-electronic.hu

GEYER ELECTRONIC AMERICA, Inc.
El Cajon / San Diego
Tel: +1 619 401-4038 Fax: 1 619 401-4095 e-mail: sales@geyer-usa.com

GEYER ELECTRONIC India Office
Bangalore
Tel: +91 80 23210173 Cellphone: 9880213077 e-mail: raghavendra@geyer-india.com

GEYER ELECTRONIC (Asia) Pte. Ltd.
Singapore
Tel: +65 6766 6938 Fax: +65 6766 6392 e-mail: sales@geyer-electronic.net

GEYER ELECTRONIC Taiwan Office
Taipei
Tel: +886 2 5582 5888 e-mail: sales6@geyer-electronic.net

General Terms and Conditions of Sale of GEYER ELECTRONIC e. K (Rev. 01/2016)

I. Scope of Validity

1. These Conditions shall apply exclusively to all our offers, supplies and services to our Customer. These Conditions shall also apply for future orders, supplies and services without the need of any express agreement thereon at the conclusion of such transaction.
2. Any conditions of the Customer, which differ from our Conditions shall not be recognized, whether or not we have objected to such conditions. Our Conditions shall also apply, if we, knowing of any contradictory or dissenting conditions of our Customer, unconditionally execute the supply.
3. Our Conditions shall apply only to contractors as defined by § 310, Section 1 BGB (German Civil Code).

II. Offer and Acceptance

1. Our quotations are subject to change without notice and are not binding unless they are expressly described as being binding.
2. Any describing data of our products, such as illustrations, drawings, specifications, weights, dimensions, performance-, operational- and consumption data, loading capacities, tolerances, and information relating to the use or suitability for a particular application, contained in our offer, in prospectus, catalogues or similar documents, constitute an approximate guide and shall not be binding unless expressly described as binding. Any such data relate to serial products which have been tested under central European operation conditions and describe their standard functions. They are not to be deemed guaranteed properties but are descriptions or definitions of the goods or services.
3. Customary changes in quantities, quality or specifications of the goods, changes as a result of a change of law and technical improvements shall be allowed. We may also replace parts of the goods with other equal parts provided such parts do not impair their suitability for the purpose provided for by the contract.
4. We reserve the right of ownership and copyright of all quotation documents; they may not be made available to third parties unless upon our approval.
5. Offers made by the Customer shall be in writing (letter, telefax, e-mail).
6. We may accept an order made by a Customer within 4 weeks after its receipt, which shall be confirmed in writing.

III. Prices and Terms of Payment

1. The prices quoted by us are in EURO and are given on the basis ex works (EXW as per Incoterms 2000) for deliveries within and outside Germany, subject to the provisions under Section IV.1 hereunder. Value added tax shall be added at the rate applicable at the time of invoicing.
2. Unless otherwise agreed, the price shall be paid within 30 calendar days (without discount).
3. If the Customer is in delay in making payment, we are entitled to charge interest for late payment at the rate of 9 % p.a. above the relevant base rate of the Deutsche Bundesbank. The creditor of a remuneration has in case of default also the right to get a flat payment of 40 Euro. If we are able to demonstrate a greater loss as a result of late payment, then we are entitled to claim for this loss.
4. Any offsetting or retaining of payment by the Customer is only permitted if Customer's counterclaims are not contested or have been finally decided by the court.

IV. Delivery

1. Deliveries within Germany and outside Germany shall be made Ex Works (EXW according to Incoterms 2000). The means of shipment shall be at our sole discretion. We will deliver in customary packaging. Unless otherwise agreed upon, we will charge the Customer for all shipment and packaging costs as accrued. At the request of the Customer, the deliveries will be insured by us at his expense.
2. We are entitled to make partial deliveries.
3. We are entitled to charge the Customer for costs incurred by us due to Customer's failure to accept the goods or because of false information given by him.
4. The minimum order value for shipments shall be EURO 25,- (without VAT).

V. Transfer of Risk

1. The risk of accidental loss and accidental deterioration of the goods passes to the Customer when the goods are ready for shipment.
2. If the delivery is delayed due to circumstances for which the Customer is responsible for, the risk passes over to him from the date of readiness for shipment.

VI. Transportation Damages

1. The Customer shall give notice in writing without delay to us as well as to the carrier or such other party in charge of the transport of any transport damage within the following time-limits :

In case of damaged packaging :

- a) Mail :The damage needs to be confirmed upon handing over and to be notified at the post office within 24 hours (!). The damage needs to be notified to us within 48 hours.
- b) Parcel Post :The damaged goods need to be unpacked in the presence of the driver and the damage needs to be confirmed by him. The damage is to be notified to us within 48 hours.
- c) Transport: The damaged goods need to be unpacked in the presence of the driver and the damage needs to be confirmed on the bill of lading. The damage is to be notified to us within 48 hours.

In case of undamaged packaging :

- a) Mail: Immediately (within 24 hours) the post office in charge needs to be notified and an inspection and a finding of facts is to be applied for. The damage is to be notified to us within 48 hours.
- b) Parcel Post: The damage is to be notified to us within 48 hours.
- c) Transport :The damaged goods need to be unpacked in the presence of the driver and the damage needs to be confirmed on the bill of lading, indicating that the packaging has been undamaged prior to the ascertainment of the damage. The damage is to be notified to us within 48 hours.

VII. Delivery Time

1. Compliance with the agreed due dates for delivery requires that the Customer has fulfilled all his obligations in good time and in the appropriate way.
2. The delivery time has been complied with if by the end of the delivery period, the ordered goods have been handed over to the Customer, or the carrier or the other party in charge of the transport, or is ready for shipment and this has been notified to the Customer.
3. If non-compliance with an agreed delivery period is due to force majeure or other circumstances for which we are not responsible, the delivery period will be extended by the duration of such events.
4. If a delivery is in delay due to circumstances for which we are responsible for, or becomes impossible, our liability for damages shall be limited in accordance with the provisions of Section X hereunder.

VIII. Retention of Title

1. The property of all goods supplied shall remain with us until all amounts outstanding to us under the business relationship with the Customer are fully paid. In the event of a breach of contract by the Customer, especially in case of default of payment or in case of enforcement measures by third parties, we are entitled to demand return of the goods. Return of the goods or their seizure shall not be deemed termination or cancellation of the contract, unless we have expressly declared so. We are entitled to the sale or any other use or exploitation of such returned goods.
2. The Customer may neither pledge nor assign the goods by way of security. The Customer shall notify us immediately in the event of seizures or other enforcement measures by third parties to the goods.
3. The Customer is entitled to resell the goods in the ordinary course of business. Once the goods are resold, payment claims by the customer against his own buyer as a result of the resale are deemed to have been assigned to us, whether or not such goods have been incorporated into, processed or mixed with other goods. We herewith accept such assignment. Upon assignment the Customer shall be entitled to collect any receivables arising from the resale of the goods. We reserve our right to collect such receivables by ourselves in case the Customer fails to fulfill his payment obligations.
4. Any processing of the goods shall always be made in our name and for our behalf. In case the goods are incorporated into or mixed with other goods not belonging to us, we will become the co-owner of such other goods in relation of the value of our goods to the value of the other goods.
5. We undertake to release the securities due to us at the request of the Customer in so far as their value exceed the secured debts by more than 20 %, in so far as these have not yet been settled.

IX. Liability for Defects

1. We accept liability for defects of the goods or services supplied only if the Customer has complied with his legal inspection and notification duties. The Customer shall inspect the goods without delay upon delivery and shall give notice to us of any defect without delay. If the Customer fails to give such notice, the goods shall be conclusively accepted, except for a defect which has not been detectable during inspection.
2. In case of a defect, we shall make good such defect at our option by repair or by the supply of a replacement. In case of repair we will bear all expenses necessary for such repair, except those expenses which are the result of the goods being transferred to another location than the place of performance agreed upon.
3. If repair or replacement is unsuccessful, the Customer is entitled, at his option, to demand a corresponding reduction in the purchase price or cancellation of the contract.
4. No claims for defects can be made in case of minor deviations from the properties agreed upon or in case of a minor impairment of the suitability, in case of normal wear and tear, in case of damages resulting from misuse, use of unsuitable operating materials, in case of external influences, which have not been agreed upon or have not been a condition of the contract, or in case of defects of the software which cannot be reproduced.
5. This liability for defects does also not apply if the Customer modifies the goods without our consent or has them modified by third parties and such modification makes the remedy more difficult or impossible. In either case the Customer shall be liable for the additional expenses incurred due to such modification.
6. In case of defects in goods as are not of our manufacture, we are entitled at our option to pursue our warranty claims against the manufacturer or supplier of such goods or to assign such claims to our Customer. The Customer may claim against us in case of such defects only, if Customers claim against the supplier or manufacturer has been unsuccessful or, for instance due to insolvency, is unpromising.
7. Claims for defects hereunder are always subject to the return of defective parts by the Customer to us.
8. The defects liability period is one (1) year from delivery of the goods.
9. Used goods are sold without any liability for defects.
10. We are not giving the Customer any guarantees within the legal meaning of the word, unless we expressly grant such a guarantee in a given case.
11. The provisions under Section X – Liability apply to any claims for damages by the Customer.

X. Liability

1. Our liability for damages or compensation, irrespective of the legal ground, in particular with respect to impossibility of performance, delays, defective or false supply, breach of contract, defective or non performed consulting or information, breach of duties in negotiations and wrongful acts, in so far as negligence is legally required, shall be limited to the extent set forth in this Section X.
 2. We shall not be liable in case of ordinary negligence on the part of our managing director, legal representatives, executives or other agents.
 3. We are liable under the legal provisions, if the damage was caused by negligent breach of a major contractual obligation (cardinal obligation); in such a case our liability for compensation shall be limited to the foreseeable damage that may typically occur. Cardinal obligations are understood to be obligations, which are mandatory for the proper performance of the contract and upon which the Customer could rely upon on a regular basis.
 4. The foregoing limitations and exclusions of liability shall not apply in case of guaranteed properties, not in case of physical injuries or damage to health or loss of life for which we are responsible for and shall also not apply for claims made by the Customer under product liability.
- ## XI. Waste Disposal under the German Electrical and Electronic Appliances Act
1. If the goods are subject to the German Electrical and Electronic Appliances Act, we offer to our Customer the option to carry out for him the waste disposal as stipulated by law. This service is provided against reimbursement of the actual cost that have been incurred and on condition that it has been requested in writing at the time of the purchase contract. Otherwise the Customer himself shall be liable for the correct legally stipulated waste disposal of the delivered goods at his own expense upon the termination of use of the goods.
 2. In such a case the Customer shall indemnify us and our suppliers against any duties arising from section 10 II of the German Electrical and Electronic Appliances Act (Reacceptance Duty of the Manufacturer) and thus also against any associated third-party claims.
 3. The Customer shall impose a contractual commitment on any third-party contractor to which he passes on the delivered good, specifying that the third party shall, at its own expense, ensure the correct legally stipulated waste disposal of the delivered good upon termination of use and that the third party shall furthermore impose the same commitment on further third parties in case that the relevant goods are passed on further. If the customer fails to impose a waste disposal commitment and a passing-on duty in respect of this commitment in his relationship with third-party contractors to which he passes on the delivered goods, then the Customer shall be liable to reaccept the delivered goods upon termination of use at his own expense and to ensure correct legally stipulated waste disposal of the same. If the Customer passes on the goods to non contractors, then the provisions of Section XI.2 here above shall apply.
 4. Our claim towards Customer for take-over/indemnification shall not become subject to statute-barring until the expiration of two years following the final termination of use of the goods. This period shall start no earlier than our receipt of written notification from the Customer and/or from the Customer's customer concerning termination of use.

XII. Final Provisions

1. In the case of disputes arising out of the business relationship with contractors, München is agreed as the legal venue, or, at our option, the principal place of business of our Customer.
2. Unless otherwise agreed, the place of performance is München.
3. The laws of the Federal Republic of Germany shall apply. The provisions of the United Nations Convention on Contracts for the International Sale of Goods do not apply.

GEYER ELECTRONIC e.K.