



GV General purpose Series

- Features : 85°C 2000 hours & Low profile vertical chip
- Recommended Applications: Suitable for AV(TV, Video, Audio), Monitor/Computer, Home appliance, OA/HA/Communication
- Corresponding product to RoHS



Specifications

Item	Characteristics																																								
Operating Temperature Range	-40 ~ +85°C																																								
Rated Voltage Range (WV)	4 ~ 100VDC																																								
Capacitance Range	0.1 ~ 1000 μF																																								
Capacitance Tolerance	± 20 % at 120Hz , 20°C																																								
Leakage Current (MAX) (20°C)	$I \leq 0.01CV$ or $3(\mu A)$, whichever is greater. (After rated voltage applied for 2 minutes) I= Leakage Current (μ A) C= Nominal Capacitance (μ F) V= Rated Voltage (V)																																								
Dissipation Factor (MAX) (tan δ) (120Hz ,20°C)	Shown in the table of standard rating																																								
Low Temperature Stability Impedance Ratio (MAX)	<table border="1"> <thead> <tr> <th>WV</th> <th>4</th> <th>6.3</th> <th>10</th> <th>16</th> <th>25</th> <th>35</th> <th>50</th> <th>63</th> <th>100</th> </tr> </thead> <tbody> <tr> <td>Z(120HZ)</td> <td></td> <td></td> <td></td> <td></td> <td></td> <td></td> <td></td> <td></td> <td></td> </tr> <tr> <td>Z(-25°C) / Z(20°C)</td> <td>7</td> <td>4</td> <td>3</td> <td>2</td> <td>2</td> <td>2</td> <td>2</td> <td>2</td> <td>2</td> </tr> <tr> <td>Z(-40°C) / Z(20°C)</td> <td>15</td> <td>8</td> <td>6</td> <td>4</td> <td>4</td> <td>3</td> <td>3</td> <td>3</td> <td>3</td> </tr> </tbody> </table>	WV	4	6.3	10	16	25	35	50	63	100	Z(120HZ)										Z(-25°C) / Z(20°C)	7	4	3	2	2	2	2	2	2	Z(-40°C) / Z(20°C)	15	8	6	4	4	3	3	3	3
WV	4	6.3	10	16	25	35	50	63	100																																
Z(120HZ)																																									
Z(-25°C) / Z(20°C)	7	4	3	2	2	2	2	2	2																																
Z(-40°C) / Z(20°C)	15	8	6	4	4	3	3	3	3																																
Endurance	After applying rated voltage for 2000hrs at 85°C , the capacitors shall meet the following requirements. <table border="1"> <tbody> <tr> <td>Capacitance Change</td> <td>Within ±20% of the initial value</td> </tr> <tr> <td>Dissipation Factor</td> <td>Not more than 200% of the specified value</td> </tr> <tr> <td>Leakage Current</td> <td>Not more than the specified value</td> </tr> </tbody> </table>	Capacitance Change	Within ±20% of the initial value	Dissipation Factor	Not more than 200% of the specified value	Leakage Current	Not more than the specified value																																		
Capacitance Change	Within ±20% of the initial value																																								
Dissipation Factor	Not more than 200% of the specified value																																								
Leakage Current	Not more than the specified value																																								
Shelf Life	After placed at 85°C without voltage applied for 1000 hours, the capacitor shall meet the same requirement as Endurance.																																								

Diagram of Dimensions(mm)

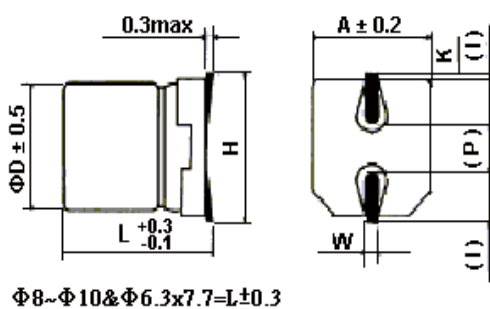

() : Reference size

φ D	L	A	H	I	W	P	K
4.0	5.4	4.3	5.5 Max	1.8	0.65±0.1	1.0±0.2	0.35 +0.15/-0.20
5.0	5.4	5.3	6.5 Max	2.2	0.65±0.1	1.5±0.2	0.35 +0.15/-0.20
6.3	5.4	6.6	7.8 Max	2.6	0.65±0.1	1.8±0.2	0.35 +0.15/-0.20
6.3	7.7	6.6	7.8 Max	2.6	0.65±0.1	1.8±0.2	0.35 +0.15/-0.20
8.0	6.2	8.3	9.5 Max	3.4	0.65±0.1	2.2±0.2	0.35 +0.15/-0.20
8.0	10.2	8.3	10.0 Max	3.4	0.90±0.2	3.1±0.2	0.70±0.20
10.0	10.2	10.3	12.0 Max	3.5	0.90±0.2	4.6±0.2	0.70±0.20

Multiplier for Ripple Current

Frequency coefficient

Frequency (Hz)	60	120	1K	10K
Coefficient	0.80	1.00	1.15	1.25

Temperature coefficient

Ambient Temperature (°C)	≤ 50	70	85
Coefficient	1.36	1.25	1



GV General purpose Series

■ Dimensions, Max Dissipation Factor, Max Permissible Ripple Current, Max Equivalent Series Resistance

Capacitance (μF)	Rated (Surge) Voltage															
	4(5)				6.3(8)				10(13)				16(20)			
	Size	tan δ	Ripple	ESR	Size	tan δ	Ripple	ESR	Size	tan δ	Ripple	ESR	Size	tan δ	Ripple	ESR
4.7													4x5.4	0.16	20	45.1
10													4x5.4	0.16	28	21.1
22	4x5.4	0.35	19	21.1	4x5.4	0.26	20	15.6	4x5.4	0.30	28	18	4x5.4	0.26	27	15.6
													5x5.4	0.16	39	9.64
33	4x5.4	0.35	26	14.0	5x5.4	0.26	22	10.4	4x5.4	0.30	29	12	5x5.4	0.26	45	10.4
													5x5.4	0.20	43	8.03
47	4x5.4	0.35	34	9.87	5x5.4	0.26	46	7.33	5x5.4	0.30	43	8.46	6.3x5.4	0.16	70	4.51
													6.3x7.7	0.18	75	5.07
100	5x5.4	0.35	61	4.64	6.3x5.4	0.26	71	3.44	6.3x5.4	0.26	70	3.44	6.3x5.4	0.20	70	2.65
													6.3x7.7	0.20	85	2.38
220	6.3x5.4	0.35	82	2.11	6.3x7.7	0.35	235	2.11	6.3x7.7	0.26	105	1.32	6.3x7.7	0.20	105	1.08
					8x6.2	0.35	250	2.11	8x6.2	0.26	250	1.56	8x10.2	0.20	280	1.20
330					6.3x7.7	0.35	280	1.40	8x10.2	0.26	330	1.04	10x10.2	0.20	380	0.80
					8x6.2	0.35	300	1.40								
470					8x10.2	0.35	380	0.99	10x10.2	0.26	400	0.73	10x10.2	0.20	420	0.56
1000					10x10.2	0.35	700	0.46	10x10.2	0.26	580	0.34				

Capacitance (μF)	Rated (Surge) Voltage											
	25(32)				35(44)				50(63)			
	Size	tan δ	Ripple	ESR	Size	tan δ	Ripple	ESR	Size	tan δ	Ripple	ESR
0.1									4x5.4	0.12	1	1593
0.22									4x5.4	0.12	2	723
0.33									4x5.4	0.12	3	482
0.47									4x5.4	0.12	5	338
1									4x5.4	0.12	10	159
2.2					4x5.4	0.12	8	72.3	4x5.4	0.12	16	72.3
3.3					4x5.4	0.12	10	48.2	4x5.4	0.12	16	48.2
4.7	4x5.4	0.14	22	39.5	4x5.4	0.12	22	33.8	5x5.4	0.12	23	33.8
10	4x5.4	0.20	24	26.5	4x5.4	0.16	24	21.2	6.3x5.4	0.12	35	15.9
	5x5.4	0.14	28	18.5	5x5.4	0.12	30	15.9				
22	6.3x5.4	0.14	55	8.44	6.3x5.4	0.12	60	7.23	6.3x7.7	0.12	90	7.23
									8x6.2	0.12	110	7.23
33	6.3x5.4	0.14	65	5.62	8x6.2	0.14	130	5.62	6.3x7.7	0.12	90	4.82
									8x10.2	0.12	120	4.82
47	6.3x5.4	0.20	70	5.64	8x6.2	0.14	165	3.95	6.3x7.7	0.12	63	3.38
	8x6.2	0.16	96	4.51					10x10.2	0.12	130	3.38
100	6.3x7.7	0.16	115	2.12	6.3x7.7	0.14	140	1.85	10x10.2	0.12	190	1.59
	8x10.2	0.16	180	2.12	10x10.2	0.14	210	1.85				
220	10x10.2	0.16	310	0.96	10x10.2	0.14	310	0.84				

Capacitance (μF)	Rated (Surge) Voltage							
	63(79)				100(125)			
	Size	tan δ	Ripple	ESR	Size	tan δ	Ripple	ESR
3.3					8x10.2	0.18	30	72.3
4.7	6.3x5.4	0.18	20	50.8	8x10.2	0.18	50	50.8
10	6.3x5.4	0.18	20	23.8	8x10.2	0.18	55	23.8
22	8x10.2	0.18	30	10.8	10x10.2	0.18	60	10.8
33	8x10.2	0.18	30	7.23	10x10.2	0.18	65	7.23
47	8x10.2	0.18	30	5.08				
100	10x10.2	0.18	60	2.38				

☆Size: D φ x L (mm). ☆tan δ :20°C ,120Hz. ☆Ripple Current: 85°C ,120Hz, (mA/rms) ☆ESR:20°C ,120Hz, (Ω).