

APPLICATION SPECIFICATION

3.3mm PITCH W/W CONN. multiple mating key type

	Product Name	Part Number
PLUG SIDE	PLUG HOUSING	504694 series
	PLUG TERMINAL	50398, 505608 series
RECEPTACLE SIDE	RECEPTACLE HOUSING	504693 series
	RECEPTACLE TERMINAL	50397, 505607 series
RETAINER		504695 series
APPLICABLE WIRE (※)		AWG#18~28
APPLICABLE CRIMP DIE MODEL No. (※)		573163000

※ Please refer to CS-50397/50398, 5056070000-CS for further details.

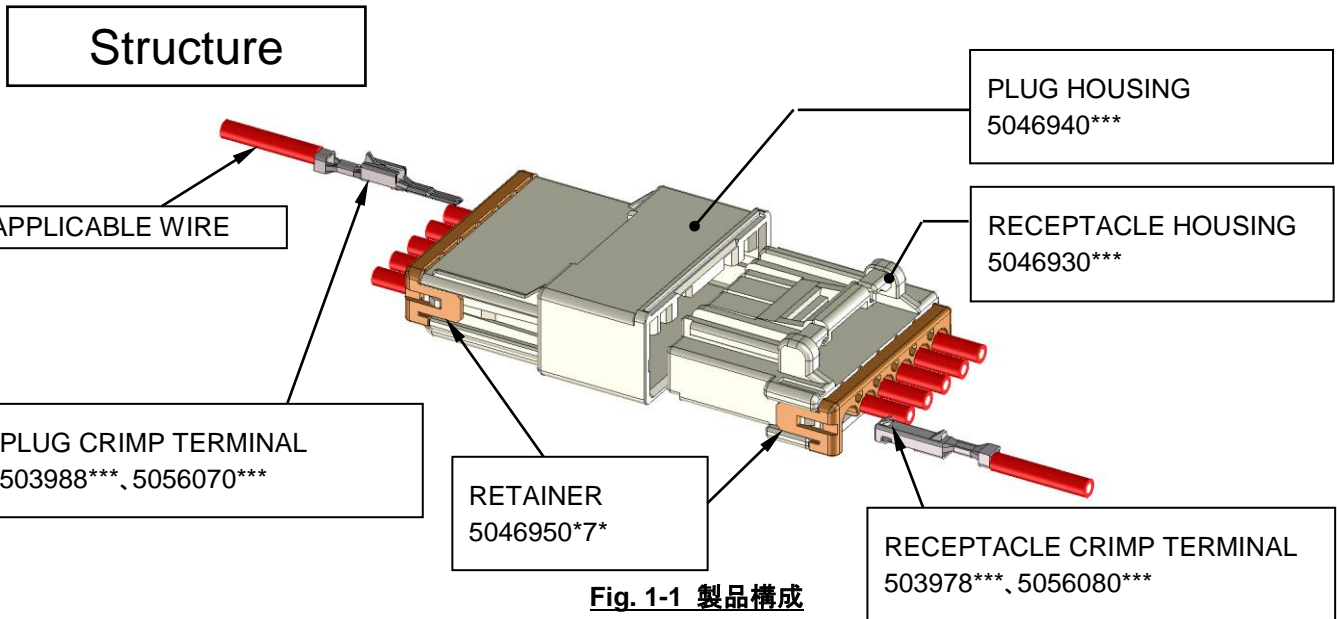

REV.	B																
SHEET	1~34																
REVISE ON PC ONLY					TITLE: <p style="text-align: center;">CP 3.3 W/W SINGLE ROW APPLICATION SPECIFICATION</p> THIS DOCUMENT CONTAINS INFORMATION THAT IS PROPRIETARY TO MOLEX ELECTRONIC TECHNOLOGIES, LLC AND SHOULD NOT BE USED WITHOUT WRITTEN PERMISSION												
B	REVISED 118386 '17/09/07 N. ITO																
REV.	DESCRIPTION																
DESIGN CONTROL J		STATUS		WRITTEN BY: T.AKAIKE	CHECKED BY: K.ASAKAWA	APPROVED BY: N.UKITA	DATE: 2014/12/05										

DOCUMENT NUMBER AS-504693-002			DOC. TYPE PS	DOC. PART 001	CUSTOMER GENERAL		SHEET 1 OF 34
-----------------------------------------	--	--	------------------------	-------------------------	----------------------------	--	------------------

— Before using —

- Be sure to read the following precautions before using connector.
- Keep this manual handy for later reference.
- The displays and illustrations shown in this manual are for illustrative purposes only, and may differ somewhat from the actual items they represent.
- The contents of this manual are subject to change without notice.
- Please call the person in charge if you find something which are causes to suspect foul play or errors.

Feature of this product

The feature of this product is the key that is different position by each color. **Each housing can only fit to another housing that has same color.** The color variation is maximum 9 at each circuit number. ○ marks indicate its key position.

REC HSG

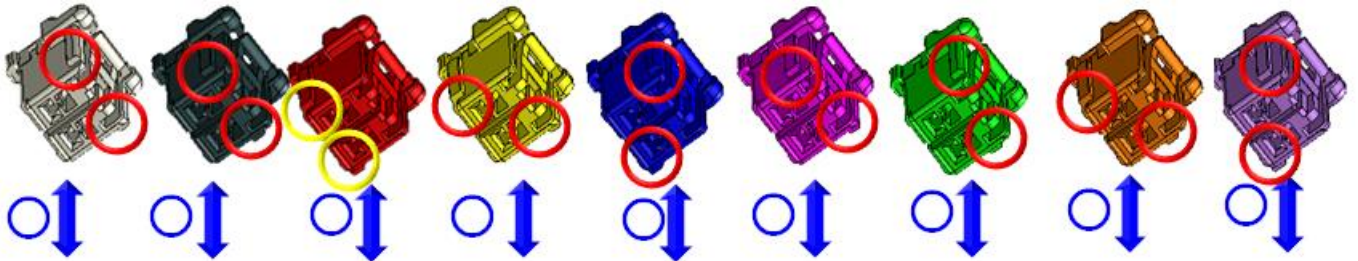

PLUG HSG

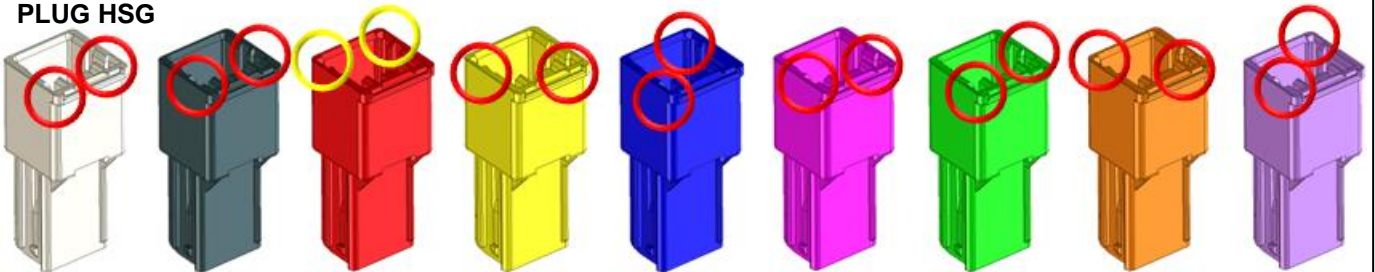

Cross sections of the mating position.



Fig. 1-2 Colors and each key position (ex. 2 circuit)

REVISE ON PC ONLY		TITLE: CP 3.3 W/W SINGLE ROW APPLICATION SPECIFICATION			
B	SEE SHEET 1 OF 34				
REV.	DESCRIPTION	THIS DOCUMENT CONTAINS INFORMATION THAT IS PROPRIETARY TO MOLEX ELECTRONIC TECHNOLOGIES, LLC AND SHOULD NOT BE USED WITHOUT WRITTEN PERMISSION			
DOCUMENT NUMBER AS-504693-002		DOC. TYPE PS	DOC. PART 001	CUSTOMER GENERAL	SHEET 2 OF 34

Contents

1. Application P-1~2

2. Instructions

2-1. Product exterior appearance P-5

2-2. Applicable wire and crimp tooling P-5

2-3. Safe-keeping before harness process P-5

2-4. Harness process instruction P-6

2-5. About use in the machinery P-7

2-6. About rating / performance standard. P-7

2-7. Use of the product. P-8

3. The name of each part & explanation

3-1. Plug crimp terminal : 50398 series. P-9

3-2. Receptacle crimp terminal : 50397 series. P-10

3-3. Plug housing : 504694 series. P-11

3-4. Receptacle housing : 504693 P-12

3-5. Retainer (Option) : 504695 P-12

4. Confirmation items of crimping wire

4-1. The exterior appearance before crimping P-13

4-2. The exterior appearance after crimping P-13

4-3. The crimping failure item P-14~16

5. Binding for over crimping-wire and package P-17

6. Harness processing

6-1. Insertion of crimping wire P-18~22

6-2. Insertion retainer (Option) P-22~23

6-3. For repairing of crimping terminal

6-3-1. Remove crimping wire from housing P-24

6-3-2. Repair of crimp terminal (Option) P-25

REVISE ON PC ONLY		TITLE: CP 3.3 W/W SINGLE ROW APPLICATION SPECIFICATION	THIS DOCUMENT CONTAINS INFORMATION THAT IS PROPRIETARY TO MOLEX ELECTRONIC TECHNOLOGIES, LLC AND SHOULD NOT BE USED WITHOUT WRITTEN PERMISSION
B	SEE SHEET 1 OF 34		
REV.	DESCRIPTION		
DOCUMENT NUMBER AS-504693-002		DOC. TYPE PS	DOC. PART 001
		CUSTOMER GENERAL	SHEET 3 OF 34
EN-127(2015-12)			

7. Binding of harness P-26

8. Packing method of harness P-27~28

9. Instruction when mating with connector

9-1. Mating process method P-29~30

9-2. Recommended de-mating method P-31

9-3. Wiring after mating P-32~33

REVISE ON PC ONLY		TITLE: CP 3.3 W/W SINGLE ROW APPLICATION SPECIFICATION	THIS DOCUMENT CONTAINS INFORMATION THAT IS PROPRIETARY TO MOLEX ELECTRONIC TECHNOLOGIES, LLC AND SHOULD NOT BE USED WITHOUT WRITTEN PERMISSION		
B	SEE SHEET 1 OF 34				
REV.	DESCRIPTION				
DOCUMENT NUMBER AS-504693-002		DOC. TYPE PS	DOC. PART 001	CUSTOMER GENERAL	SHEET 4 OF 34
EN-127(2015-12)					

[2. Instructions]

2-1. Product exterior appearance

- ① There is no influence in the product performance though the black spots or bubbles etc. might be confirmed to the plastic part of this product and the shade might be different (discoloration by aged due to aging etc.).
- ② The wiping marks sometimes appear in terminal, but this has no influence to the function of this product.

2-2. Applicable wire and crimp tooling

- ① Guarantee is void when product is used with wire is not conforming with product specifications.
- ② Guarantee is void when product is used with tooling which is not specified by Molex.
- ③ The recommended electric wire is tinned plating. Please confirm separately about the use of other electric wires.

2-3. Safe-keeping before harness process

- ① Please keep products with the delivery being in a state. And please safe-keeping it under normal temperature and humidity where avoid direct sunlight.
- ② Please do not allow external force to be applied during product storage.
- ③ During handling avoid shocking or dropping products as it may result in product damaging.
- ④ First use of older manufacturing lots is recommended.
- ⑤ Keep product in original packaging before using.
- ⑥ This product should be inspected for exterior appearance when used after expiration date.

REVISE ON PC ONLY		TITLE: CP 3.3 W/W SINGLE ROW APPLICATION SPECIFICATION			
B	SEE SHEET 1 OF 34				
REV.	DESCRIPTION	THIS DOCUMENT CONTAINS INFORMATION THAT IS PROPRIETARY TO MOLEX ELECTRONIC TECHNOLOGIES, LLC AND SHOULD NOT BE USED WITHOUT WRITTEN PERMISSION			
DOCUMENT NUMBER AS-504693-002		DOC. TYPE PS	DOC. PART 001	CUSTOMER GENERAL	SHEET 5 OF 34
EN-127(2015-12)					

2-4. Harness process instruction

- ① Please confirm products, crimp machine, crimp condition, and the applicable wire are equal to product drawing and crimp specifications before work.
- ② Beware of unintended damage caused by dust, debris, or foreign objects before using this product. It cause that connectors cannot satisfy the insertion performance to the housing and electric performance.
- ③ Please do not touch the terminal by a direct hand.
- ④ When a terminal gets twisted or tangled before or after crimping, please do not pull it forcibly. The terminal may become damaged.
- ⑤ Avoid damaging product during work in process or in finishing goods. Product can get damaged and cannot function properly as a connector.
- ⑥ Please do not put a product and harness half-finished goods in the following condition: Garbage, corrosive material, corrosive gas, high temperature, high humidity, or direct sunlight.
The above-mentioned condition causes poor contact and the corrosion of the terminal and the insulation performance deterioration of the housing. Please keep for kind attention of the safekeeping to boxes.
- ⑦ Please do not add loads to connector and harness half-finished goods during production, packaging, transportation, or storage. It may cause damage and result in poor connector performance.
- ⑧ When pulling the electric wire of harness half-finished goods, it may cause contact defectiveness by adding load to contacts, crimp parts and lock parts. **When performing the guidance wiring of the electric wire, don't exceed forces the connector can't withstand.**
- ⑨ Do not damage each housing and a crimp terminals intentionally. Product performance can be affected by this condition.
- ⑩ When opened packing, please use it up on the day. Moisture absorption or drying cause the deterioration of materials by neighboring atmospheres. When cannot use it up, please do sealing of a bag again, and keep it in a box.
- ⑪ Please be careful to injuries in the edges part such as metal parts when handling a connector.
- ⑫ To avoid injury please be careful in handling of paper between terminals and metal carrier on reels.
- ⑬ Please do not load the connector; for example, pull the cable with mating connector. It may cause damage to connectors.
- ⑭ Do not coil electric wires around the housing or the gap of the housing lock during harness processing and harness product packing. In addition, please do not pull an electric wire by force when an electric wire has coiled itself around the housing and the gap of the housing lock. If wire becomes tangled this may cause terminal damage. Please remove wires in such a way that load is not applied to housing lock.

REVISE ON PC ONLY		TITLE: CP 3.3 W/W SINGLE ROW APPLICATION SPECIFICATION			
B	SEE SHEET 1 OF 34				
REV.	DESCRIPTION	THIS DOCUMENT CONTAINS INFORMATION THAT IS PROPRIETARY TO MOLEX ELECTRONIC TECHNOLOGIES, LLC AND SHOULD NOT BE USED WITHOUT WRITTEN PERMISSION			
DOCUMENT NUMBER AS-504693-002		DOC. TYPE PS	DOC. PART 001	CUSTOMER GENERAL	SHEET 6 OF 34
EN-127(2015-12)					

2-5. About use in the machinery

- ① Vibration of an electric wire or printed circuit board due to machinery vibration or rotation must be avoided to prevent damage to connector at contact area. Contact failure due to abrasion may be caused. Therefore, please fix electric wires and printed circuit boards in the machinery and take measures to hold resonances.
- ② Please insert and withdraw connector along fixed axis. The diagonal insertion and withdrawal cause damage to the connector.
- ③ After mating, do not intentionally apply force to span or rotate a connector. Such force may cause damage to connector or solder cracking.
- ④ If an electric wire is pulled after mating a connector, it may damage contact or crimping areas or the lock area and result in contact failure. When performing the guidance wiring of the electric wire, please keep the wire loose to avoid applying excessive force to connector.
- ⑤ When withdrawing the connector, please hold wire lightly and remove the lock securely using the entire finger.
- ⑥ Plastic lances may be damaged after removing crimp terminals. Therefore, please use a new housing when repairing a connector

2-6. About rating / performance standard.

- ① Please use the product within the rating / the standard of product specification (PS-504093-001).
- ② This product is not designed for usage in “hot-swap” applications where power is on.
- ③ Please confirm that machinery design standards are satisfied before using the connector.
- ④ In order to avoid short circuits, please do not allow connectors to contact with metal objects.
- ⑤ Please avoid to use current higher than the rated current.

REVISE ON PC ONLY		TITLE: CP 3.3 W/W SINGLE ROW APPLICATION SPECIFICATION			
B	SEE SHEET 1 OF 34				
REV.	DESCRIPTION	THIS DOCUMENT CONTAINS INFORMATION THAT IS PROPRIETARY TO MOLEX ELECTRONIC TECHNOLOGIES, LLC AND SHOULD NOT BE USED WITHOUT WRITTEN PERMISSION			
DOCUMENT NUMBER AS-504693-002		DOC. TYPE PS	DOC. PART 001	CUSTOMER GENERAL	SHEET 7 OF 34
EN-127(2015-12)					

2-7. Use of the product.

- ① This product is not designed and produced for the machine to be used under the condition involving human lives or for the use of system. If you use this product for special use such as medical, aerospace and nuclear power etc., please confirm us before using.
- ② Please contact us before using if you plan to use the product for automobile and ship etc. (We will consider if the product can be applied to such specification condition.)
- ③ Please avoid using the product outdoors or under similar environment.

REVISE ON PC ONLY		TITLE: CP 3.3 W/W SINGLE ROW APPLICATION SPECIFICATION	THIS DOCUMENT CONTAINS INFORMATION THAT IS PROPRIETARY TO MOLEX ELECTRONIC TECHNOLOGIES, LLC AND SHOULD NOT BE USED WITHOUT WRITTEN PERMISSION		
B	SEE SHEET 1 OF 34				
REV.	DESCRIPTION				
DOCUMENT NUMBER AS-504693-002		DOC. TYPE PS	DOC. PART 001	CUSTOMER GENERAL	SHEET 8 OF 34
EN-127(2015-12)					

[3. The name of each part & explanation]

3-1. Plug crimp terminal : 50398, 505608 series.

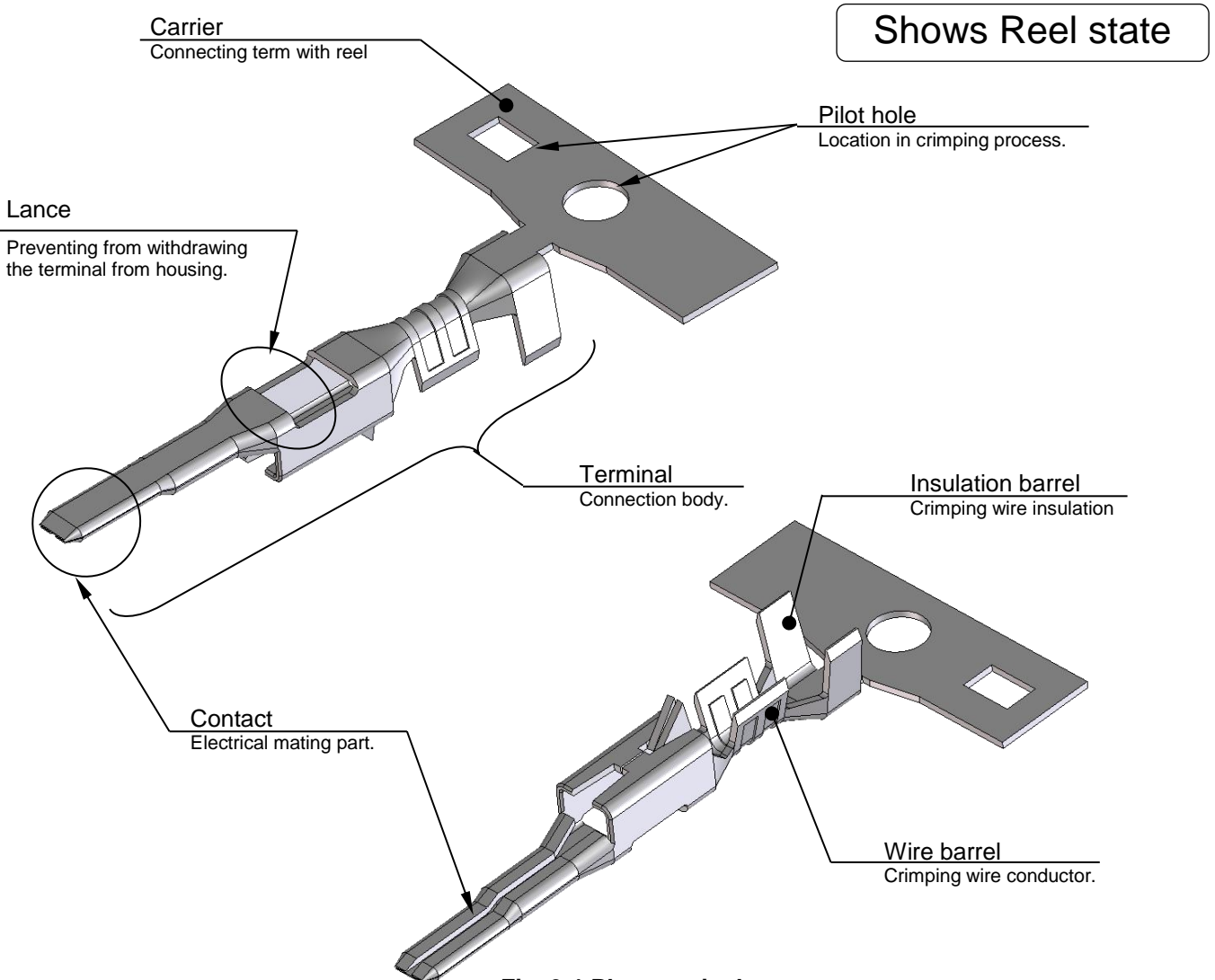

Fig. 3-1 Plug terminal

※Please refer to sales drawing (SD-50398-001, 5056080000PSD000) for product form and its dimensions.

—APPLICABLE WIRE AND APPLICABLE CRIMP DIE MODEL—

Part Number	WIRE SIZE	CONDUCTOR SPEC.
503988000	AWG#22~28	TINNED COPPER WIRE
5056080000	AWG#18~22	
APPLICABLE CRIMP DIE MODEL No.		573163000

REVISE ON PC ONLY		TITLE: CP 3.3 W/W SINGLE ROW APPLICATION SPECIFICATION			
B	SEE SHEET 1 OF 34				
REV.	DESCRIPTION	THIS DOCUMENT CONTAINS INFORMATION THAT IS PROPRIETARY TO MOLEX ELECTRONIC TECHNOLOGIES, LLC AND SHOULD NOT BE USED WITHOUT WRITTEN PERMISSION			
DOCUMENT NUMBER AS-504693-002		DOC. TYPE PS	DOC. PART 001	CUSTOMER GENERAL	SHEET 9 OF 34

3-2. Receptacle crimp terminal : 50397, 505607 series.

Shows Reel state

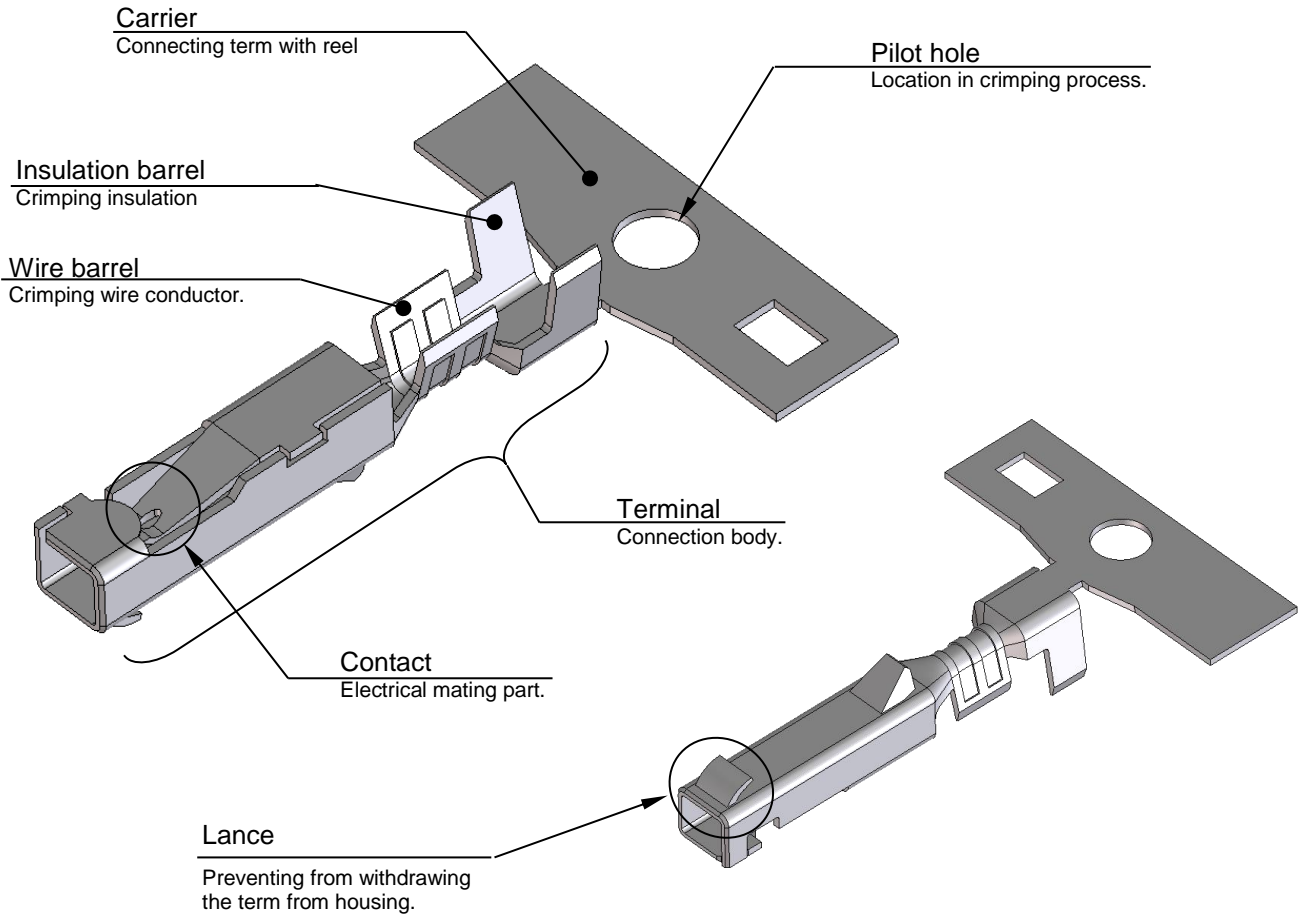

Fig. 3-2 Receptacle Terminal

※ Please refer to sales drawing (SD-50397-001, 5056070000PSD000) for product form and its dimensions.

—APPLICABLE WIRE AND APPLICABLE CRIMP DIE MODEL—

Part Number	WIRE SIZE	CONDUCTOR SPEC.
503978000	AWG#22~28	TINNED COPPER WIRE
5056070000	AWG#18~22	
APPLICABLE CRIMP DIE MODEL No.		573163000

REVISE ON PC ONLY		TITLE: CP 3.3 W/W SINGLE ROW APPLICATION SPECIFICATION			
B	SEE SHEET 1 OF 34				THIS DOCUMENT CONTAINS INFORMATION THAT IS PROPRIETARY TO MOLEX ELECTRONIC TECHNOLOGIES, LLC AND SHOULD NOT BE USED WITHOUT WRITTEN PERMISSION
REV.	DESCRIPTION	DOC. TYPE	DOC. PART	CUSTOMER	
DOCUMENT NUMBER AS-504693-002		PS	001	GENERAL	SHEET 10 OF 34

3-3. Plug housing : 504694 series.

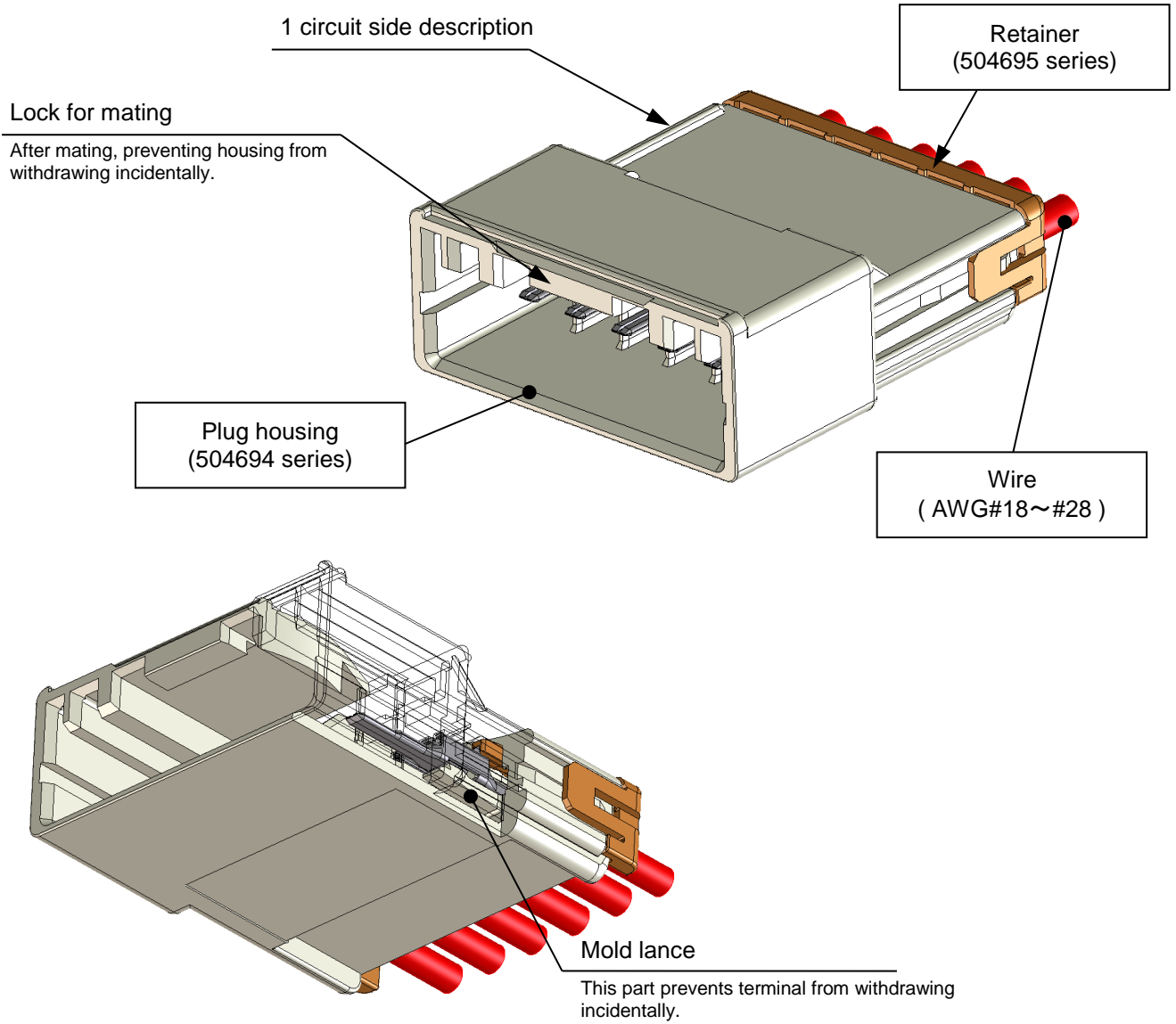

Fig. 3-3 Plug housing

※ Please refer to sales drawing (SD-504694-001) for product form and its dimensions.

REVISE ON PC ONLY		TITLE: CP 3.3 W/W SINGLE ROW APPLICATION SPECIFICATION			
B	SEE SHEET 1 OF 34				
REV.	DESCRIPTION	THIS DOCUMENT CONTAINS INFORMATION THAT IS PROPRIETARY TO MOLEX ELECTRONIC TECHNOLOGIES, LLC AND SHOULD NOT BE USED WITHOUT WRITTEN PERMISSION			
DOCUMENT NUMBER AS-504693-002		DOC. TYPE PS	DOC. PART 001	CUSTOMER GENERAL	SHEET 11 OF 34
EN-127(2015-12)					

3-4. Receptacle housing : 504693

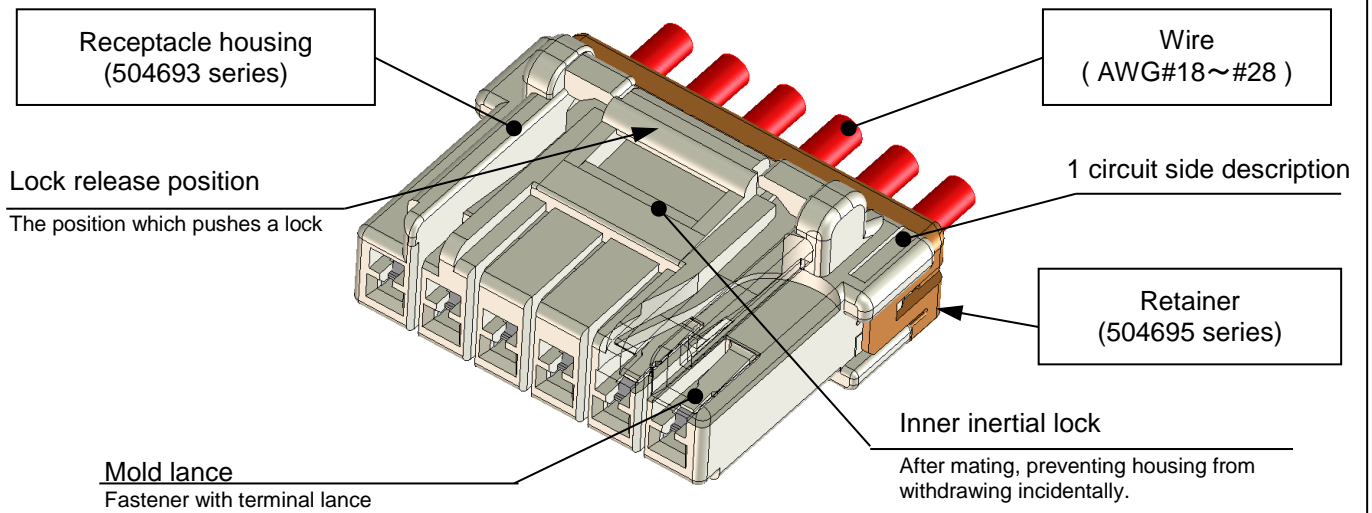

Fig. 3-4 Receptacle housing

※ Please refer to sales drawing (SD-504693-001) for product form and its dimensions.

3-5. Retainer (Option) : 504695

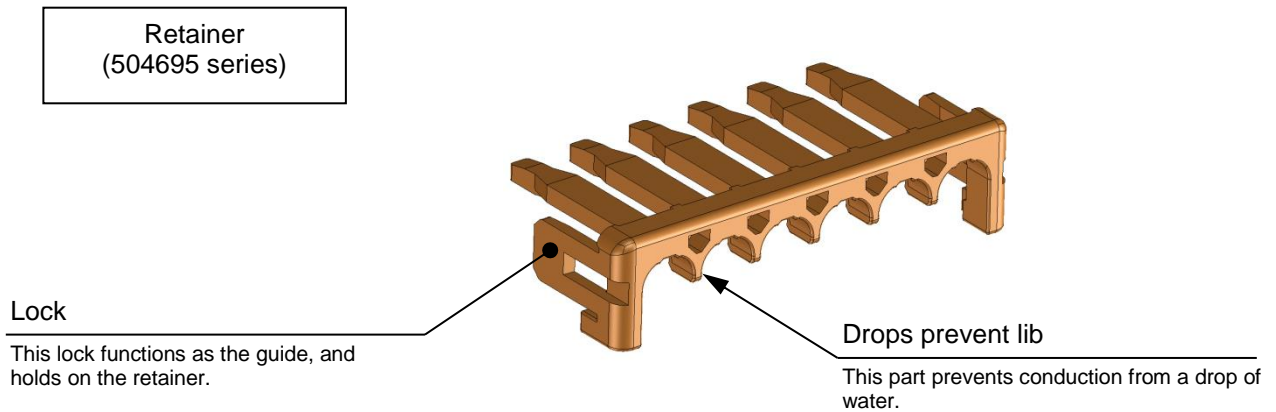

Fig. 3-5 Retainer

※ Please refer to sales drawing (5046950000PSD000) for product form and its dimensions.

REVISE ON PC ONLY		TITLE: CP 3.3 W/W SINGLE ROW APPLICATION SPECIFICATION		
B	SEE SHEET 1 OF 34			
REV.	DESCRIPTION			
THIS DOCUMENT CONTAINS INFORMATION THAT IS PROPRIETARY TO MOLEX ELECTRONIC TECHNOLOGIES, LLC AND SHOULD NOT BE USED WITHOUT WRITTEN PERMISSION				
DOCUMENT NUMBER AS-504693-002	DOC. TYPE PS	DOC. PART 001	CUSTOMER GENERAL	SHEET 12 OF 34
EN-127(2015-12)				

[4. Confirmation items of crimping wire]

4-1. The exterior appearance before crimping.

When using the loose terminals products before crimping, please make sure that there is no deformation of the crimp Terminal.

If you find that the terminals are tangled, please do not remove them forcibly.

Please refer to sales drawing (SD-50397-001, SD-50398-001, 5056070000PSD000, 5056080000PSD000) for product form and its dimensions.

4-2. The exterior appearance after crimping.

Confirmation items and crimping failure after crimping are shown as follows. Please refer to CS-50397/50398, 5056070000-CS for specified crimp height, pull testing, and applicable wire specifications.

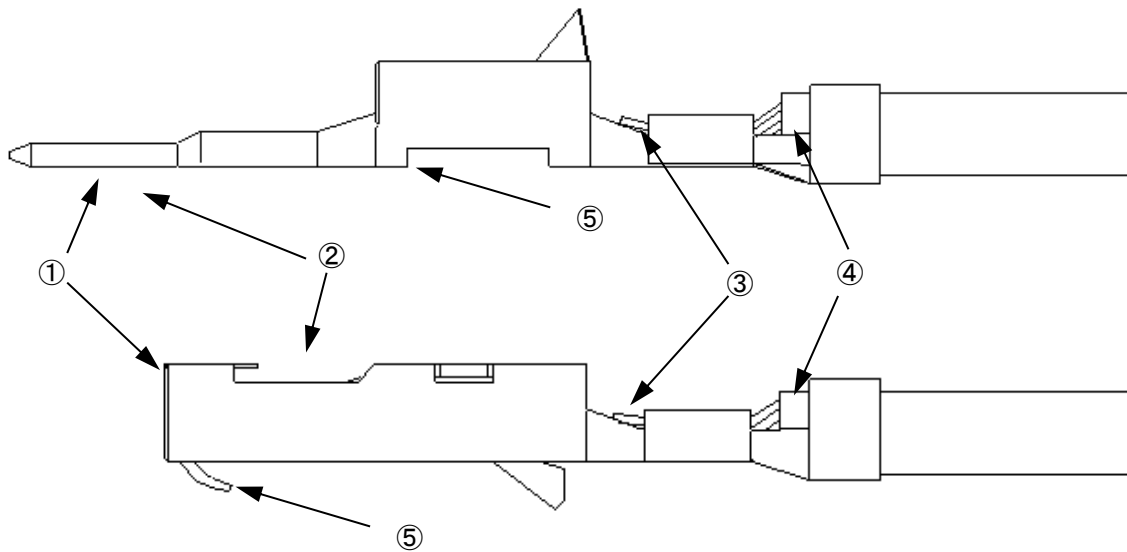

Fig. 4-1

- ① No visible damage on terminal.
- ② No visible damage or deformation on contact area and contact box.
- ③ All wire strands are in conductor barrel.
- ④ The insulator part of the electric wire is located in the intermediate position of wire barrel and insulation barrel.
- ⑤ No damage on terminal lance.
- ⑥ No damage on exterior appearance. (Dirt / foreign objects)

REVISE ON PC ONLY		TITLE:		
B	SEE SHEET 1 OF 34	CP 3.3 W/W SINGLE ROW APPLICATION SPECIFICATION		
REV.	DESCRIPTION	<small>THIS DOCUMENT CONTAINS INFORMATION THAT IS PROPRIETARY TO MOLEX ELECTRONIC TECHNOLOGIES, LLC AND SHOULD NOT BE USED WITHOUT WRITTEN PERMISSION</small>		
DOCUMENT NUMBER AS-504693-002		DOC. TYPE PS	DOC. PART 001	CUSTOMER GENERAL
				SHEET 13 OF 34
EN-127(2015-12)				

4-3. The crimping failure item

Please be careful of the crimping failure as shown below.
 It may affect the insertion to housing and affect a product function.
 Please refer to crimping viewing material (ATS-57427-0000) which writes about the details and the crimping failure items.

① **Bend up**

It may deteriorate insertion to housing and terminal retention force or cause contact failure.

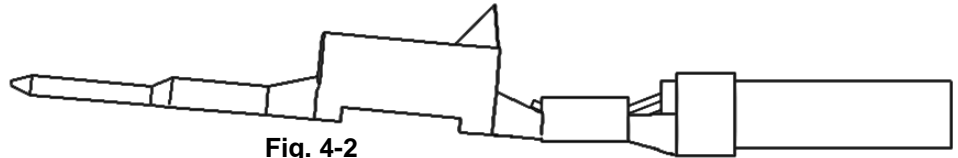

Fig. 4-2

② **Bend down**

It may deteriorate insertion to housing and terminal retention force or cause contact failure.

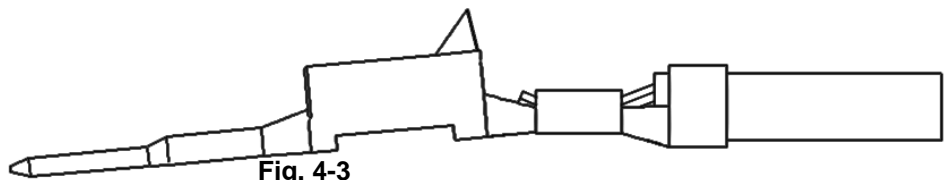
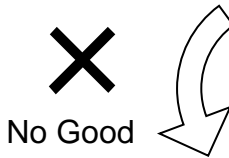

Fig. 4-3

③ **Twist**

It may deteriorate insertion to housing and terminal retention force or cause contact failure.

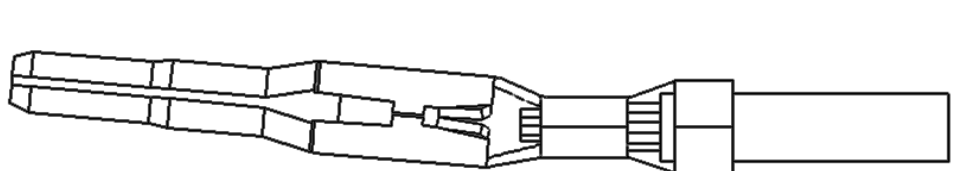
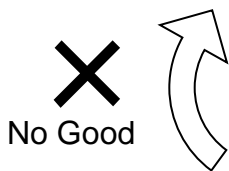
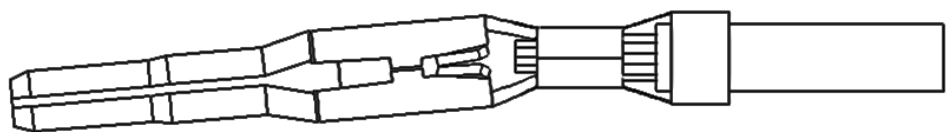
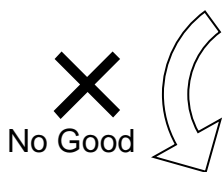
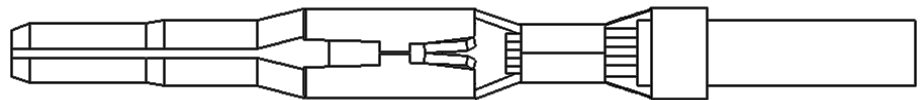

Fig. 4-4

REVISE ON PC ONLY		TITLE: CP 3.3 W/W SINGLE ROW APPLICATION SPECIFICATION			
B	SEE SHEET 1 OF 34				
REV.	DESCRIPTION	THIS DOCUMENT CONTAINS INFORMATION THAT IS PROPRIETARY TO MOLEX ELECTRONIC TECHNOLOGIES, LLC AND SHOULD NOT BE USED WITHOUT WRITTEN PERMISSION			
DOCUMENT NUMBER AS-504693-002		DOC. TYPE PS	DOC. PART 001	CUSTOMER GENERAL	SHEET 14 OF 34

④ Rolling

It may deteriorate insertion to housing and terminal retention force or cause contact failure.

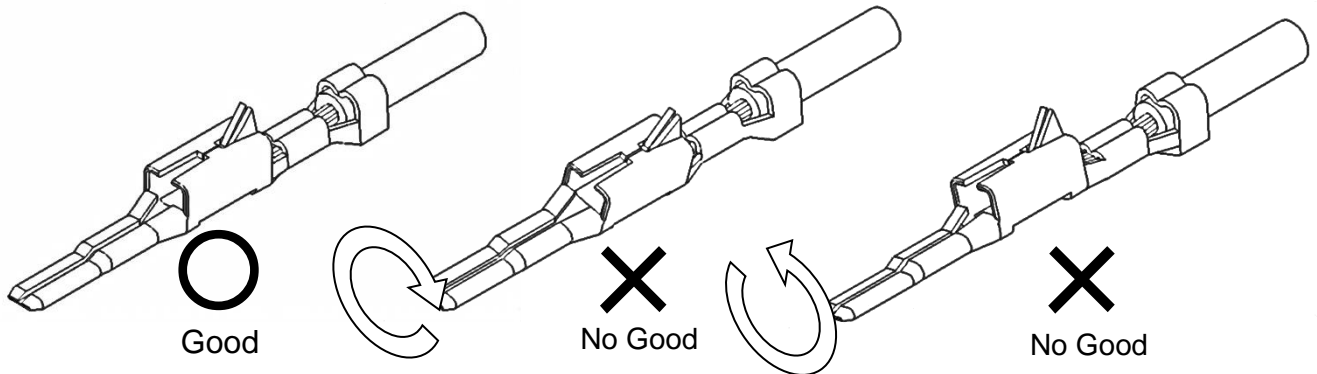

Fig. 4-5

⑤ Crush and deformation of contact area and contact box

It may deteriorate insertion to housing and terminal retention force or cause contact failure.

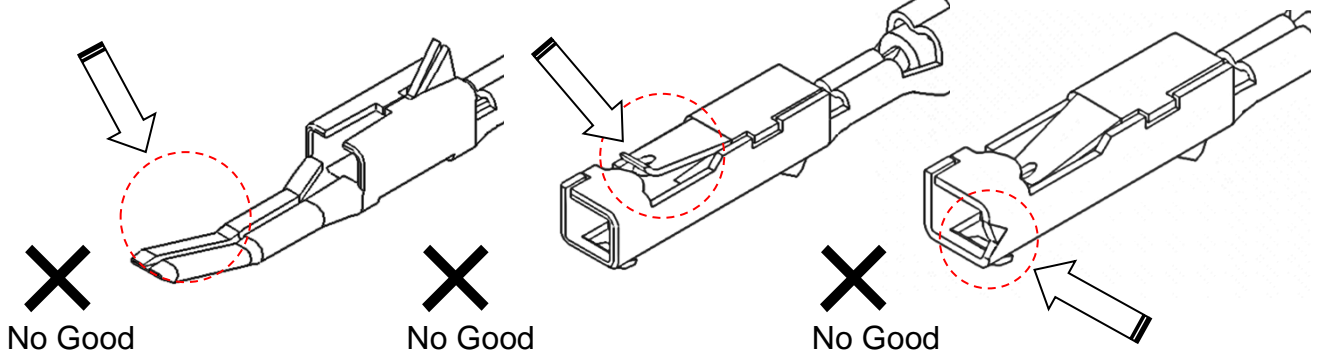

Fig. 4-6

⑥ Wire strands are not inside the conductor barrel

It may deteriorate workability and reliability of contact when insertion.

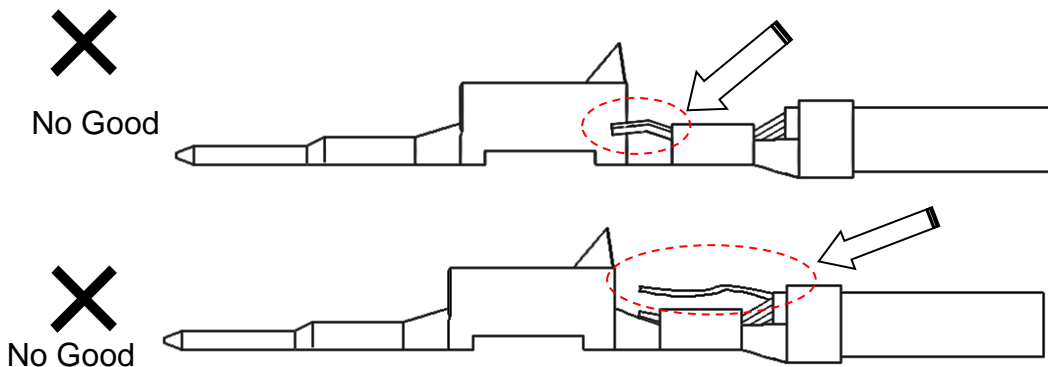

Fig. 4-7

REVISE ON PC ONLY		TITLE:		
B	SEE SHEET 1 OF 34	CP 3.3 W/W SINGLE ROW APPLICATION SPECIFICATION		
REV.	DESCRIPTION	THIS DOCUMENT CONTAINS INFORMATION THAT IS PROPRIETARY TO MOLEX ELECTRONIC TECHNOLOGIES, LLC AND SHOULD NOT BE USED WITHOUT WRITTEN PERMISSION		
DOCUMENT NUMBER AS-504693-002		DOC. TYPE PS	DOC. PART 001	CUSTOMER GENERAL
				SHEET 15 OF 34

⑦ Crimping position: Too front

It may cause breaking of wire, deterioration of wire crimping strength and disconnection by crimping insulator.

X
No Good

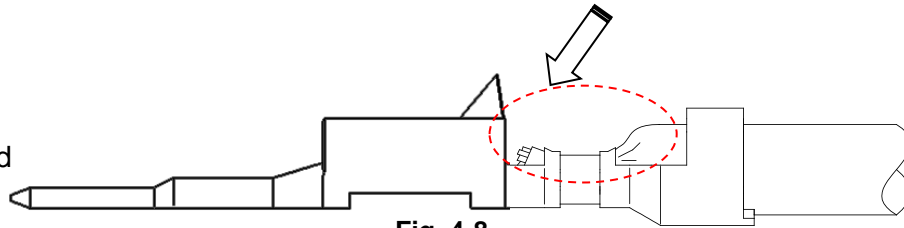

Fig. 4-8

⑧ Crimping position: Too back

It may cause deterioration of wire crimping strength and disconnection by not having enough crimping margin

X
No Good

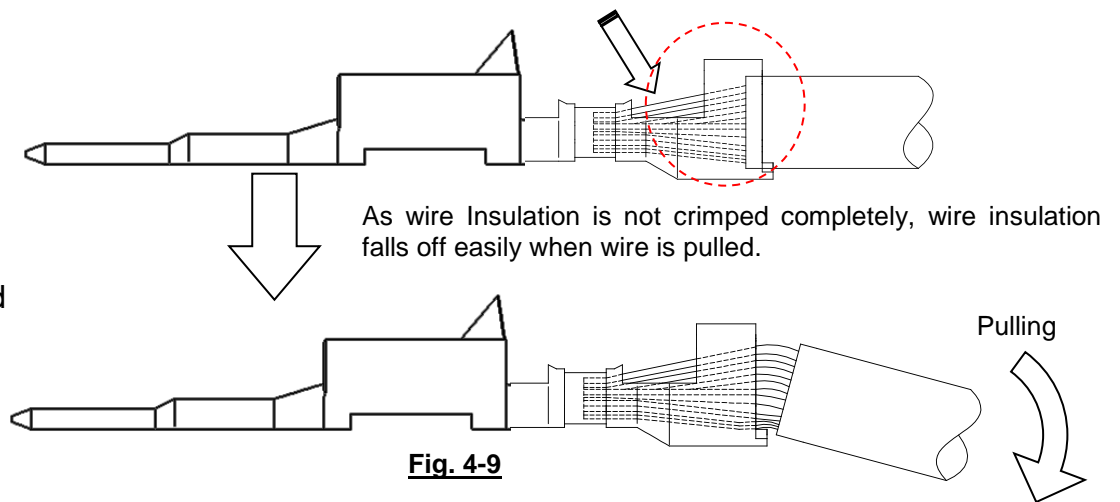
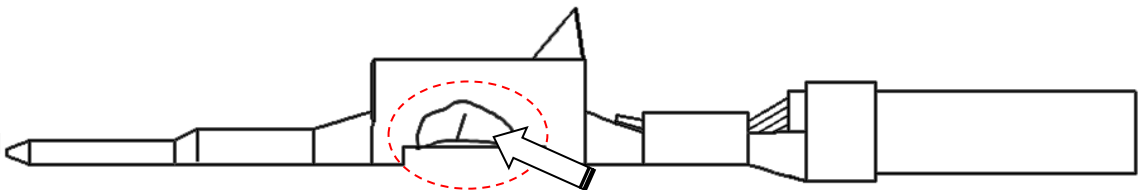

Fig. 4-9

⑨ Deformation of terminal lance

Locking of the terminal becomes insufficient and causes lowering of the terminal retention -force.

X
No Good



X
No Good

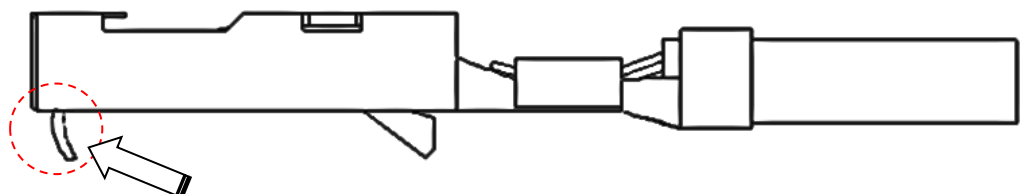

Fig. 4-10

REVISE ON PC ONLY		TITLE: CP 3.3 W/W SINGLE ROW APPLICATION SPECIFICATION	THIS DOCUMENT CONTAINS INFORMATION THAT IS PROPRIETARY TO MOLEX ELECTRONIC TECHNOLOGIES, LLC AND SHOULD NOT BE USED WITHOUT WRITTEN PERMISSION		
B	SEE SHEET 1 OF 34				
REV.	DESCRIPTION				
DOCUMENT NUMBER AS-504693-002		DOC. TYPE PS	DOC. PART 001	CUSTOMER GENERAL	SHEET 16 OF 34
EN-127(2015-12)					

[5. Binding for over crimping-wire and package]

Please check for damaged terminal and wire insulation, when bundling wires.
(We recommend you tie the wires at 20mm MIN. point from cramping parts when you tie your rubber hand. Fig.5-1)

Please check for the quantity per packing-box.

Do not over pack crimped wires in a box as there is risk of damaging terminals.

Instruction

- ※When bundling wires, please be careful not to apply excessive force to terminals.
- ※When packing bundled harnesses after processing in package box, in order for force not to be applied to connector for a long period of time by piling up, please put product alternately (cross shape)in a fitting box. **(Fig.5-2)**
- ※ Please lay buffer material on the bottom and top of the package box.
In order to avoid applying force to connector for a long period of time by stacking the wires, please lay buffer material. **(Fig.5-2)**

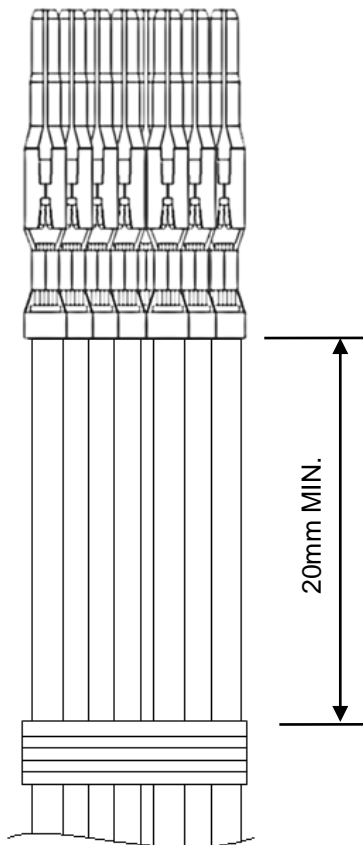

Fig. 5-1

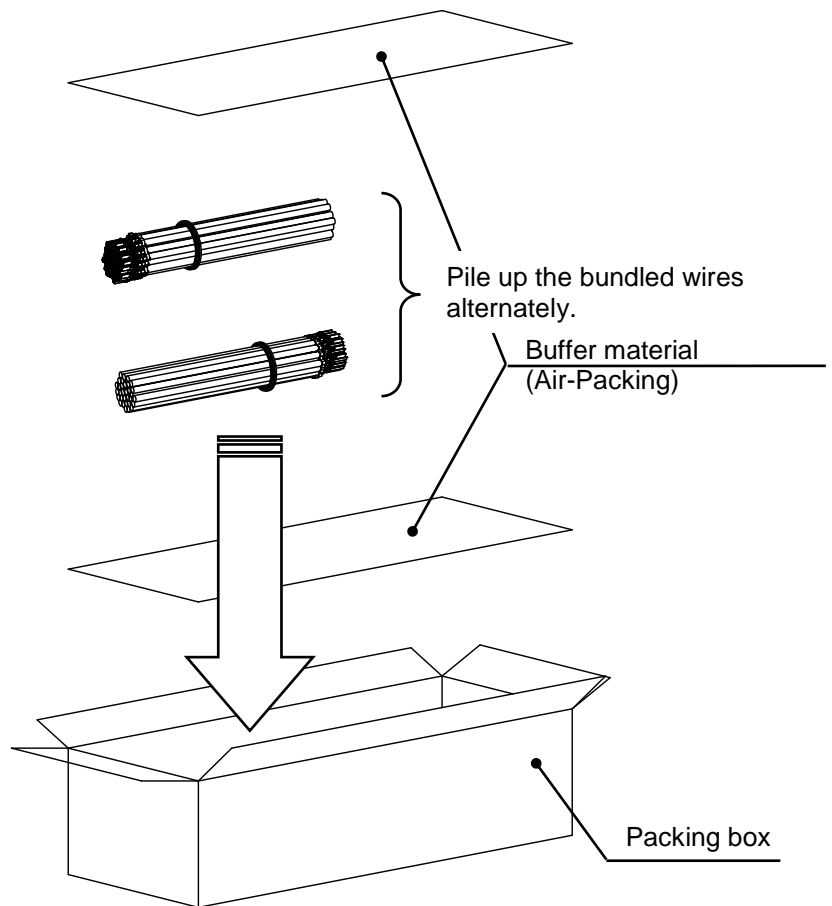

Fig. 5-2

REVISE ON PC ONLY		TITLE:		
B	SEE SHEET 1 OF 34	CP 3.3 W/W SINGLE ROW APPLICATION SPECIFICATION		
REV.	DESCRIPTION	<small>THIS DOCUMENT CONTAINS INFORMATION THAT IS PROPRIETARY TO MOLEX ELECTRONIC TECHNOLOGIES, LLC AND SHOULD NOT BE USED WITHOUT WRITTEN PERMISSION</small>		
DOCUMENT NUMBER AS-504693-002		DOC. TYPE PS	DOC. PART 001	CUSTOMER GENERAL
				SHEET 17 OF 34

[6. Harness processing (crimping wire and retainer insertion method in Receptacle housing)]

Insertion procedure and instructions (※) of the crimping wire and retainer are shown as follows:

6-1. Insertion of crimping wire

- ① Hold receptacle housing by pinching right and left side.
- ② Please hold the cable at about 10mm away from the crimp-end with a finger lightly.

Instruction

- ※ If you hold the wire at a position distant from terminal, wires will be easily bent and it may be difficult to insert.
 - ※ Distance value depends on wire gauge, UL, etc. Please confirm with the wire that you chose before using.
- ③ Hold the terminal lance part toward center of receptacle housing and insert terminal slowly and straightly till the tip of terminal touches housing (with force of around 3~6N). **(Fig.6-1)**

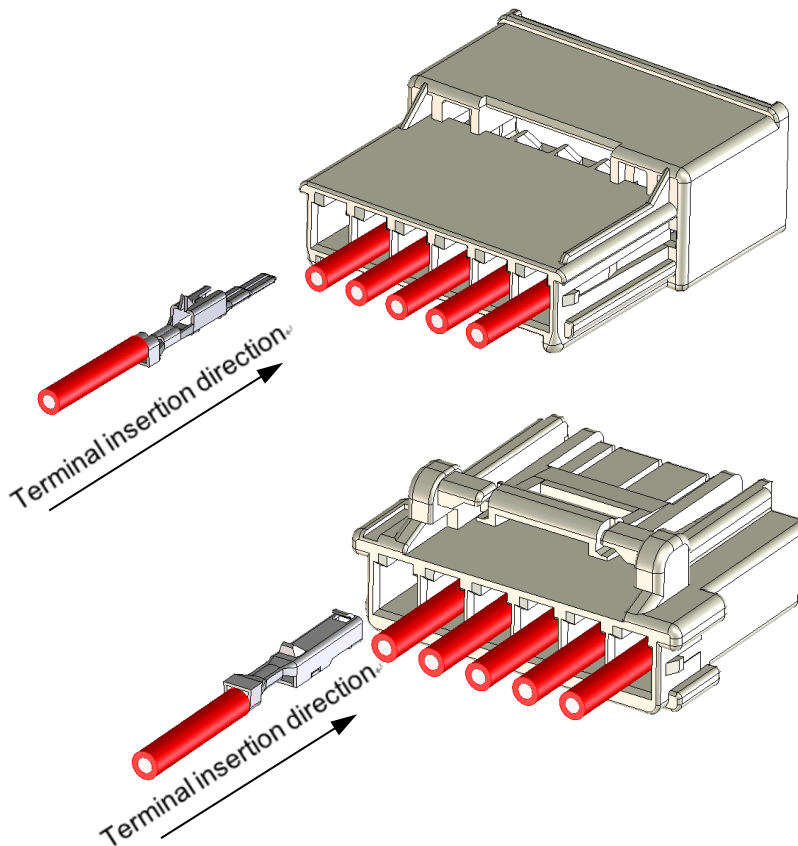
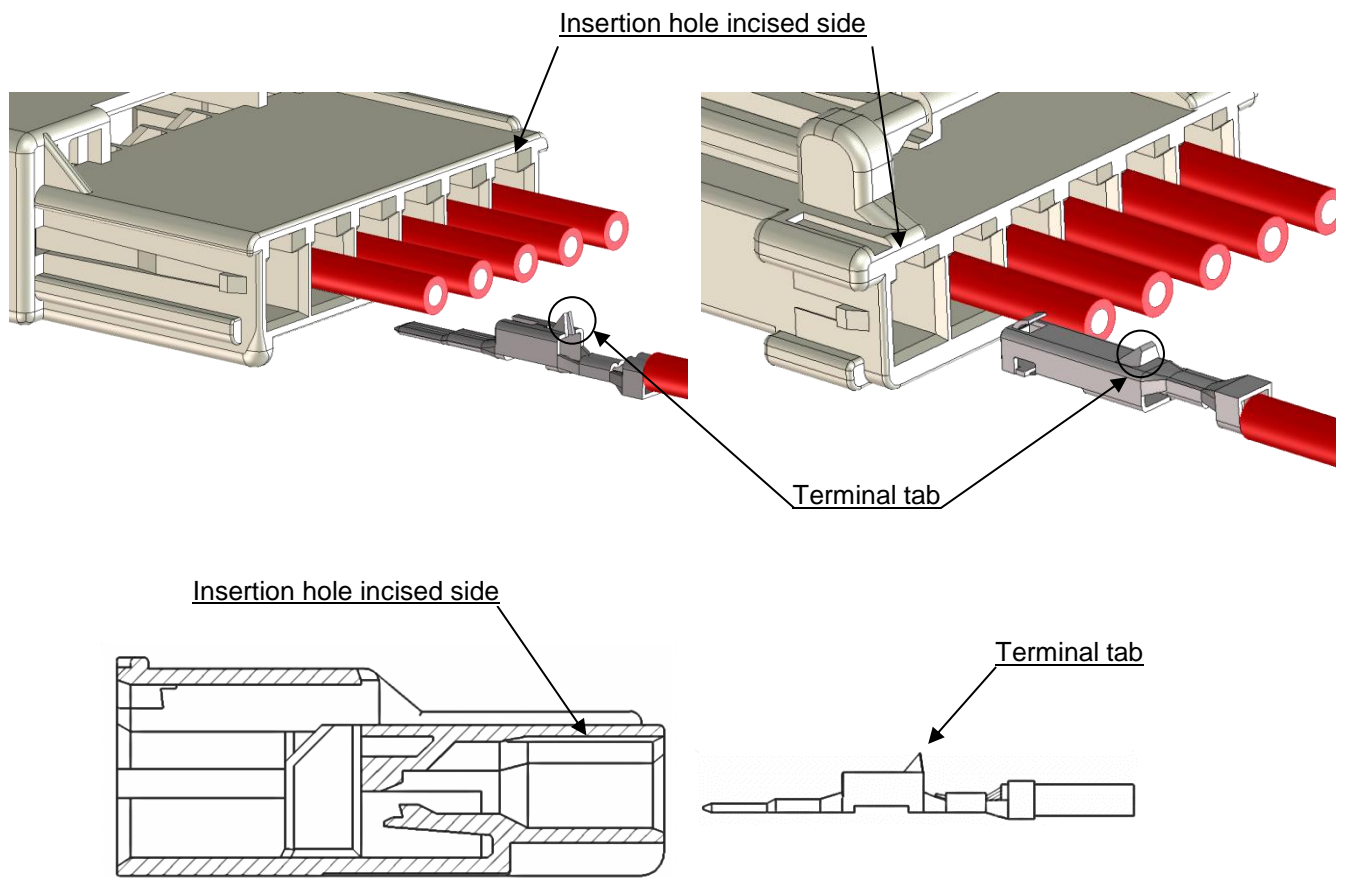

Fig. 6-1

REVISE ON PC ONLY		TITLE:		
B	SEE SHEET 1 OF 34	CP 3.3 W/W SINGLE ROW APPLICATION SPECIFICATION		
REV.	DESCRIPTION	THIS DOCUMENT CONTAINS INFORMATION THAT IS PROPRIETARY TO MOLEX ELECTRONIC TECHNOLOGIES, LLC AND SHOULD NOT BE USED WITHOUT WRITTEN PERMISSION		
DOCUMENT NUMBER AS-504693-002		DOC. TYPE PS	DOC. PART 001	CUSTOMER GENERAL
				SHEET 18 OF 34
EN-127(2015-12)				

Instruction

- ※If crimping height and width are too large, there is a problem for the terminal insertion.
Please follow the instructed crimping height.
(Please refer to crimping specifications CS -50397/50398, 5056070000-CS)
- ※ If you feel unusual such as hooking during the insertion, please do not continue by force. After confirming there is no damage of terminal or receptacle housing, it can be inserted again. If the damage is found, do not use the terminal and receptacle housing.
- ※ Please use care with the direction of terminal when inserting to receptacle housing. **(Fig.6-2,6-3)** Please be careful that the terminal is not upside down, not having an angle, or not rotated against receptacle housing. These may cause terminal deformation or damage to receptacle housing.



○ **Fig.6-2 Right insertion direction**

REVISE ON PC ONLY		TITLE:		
B	SEE SHEET 1 OF 34	CP 3.3 W/W SINGLE ROW APPLICATION SPECIFICATION		
REV.	DESCRIPTION	THIS DOCUMENT CONTAINS INFORMATION THAT IS PROPRIETARY TO MOLEX ELECTRONIC TECHNOLOGIES, LLC AND SHOULD NOT BE USED WITHOUT WRITTEN PERMISSION		
DOCUMENT NUMBER AS-504693-002		DOC. TYPE PS	DOC. PART 001	CUSTOMER GENERAL
				SHEET 19 OF 34
EN-127(2015-12)				

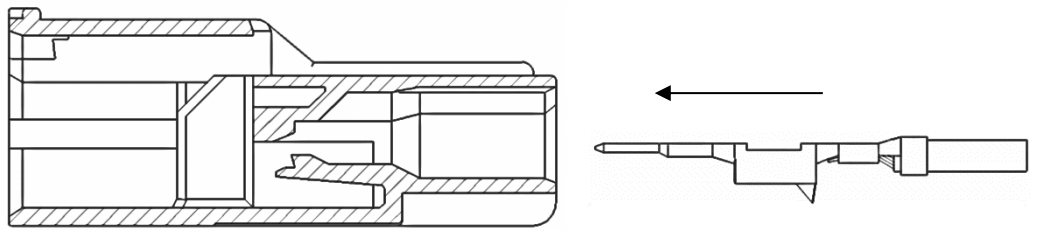

✗ Up and down opposite direction

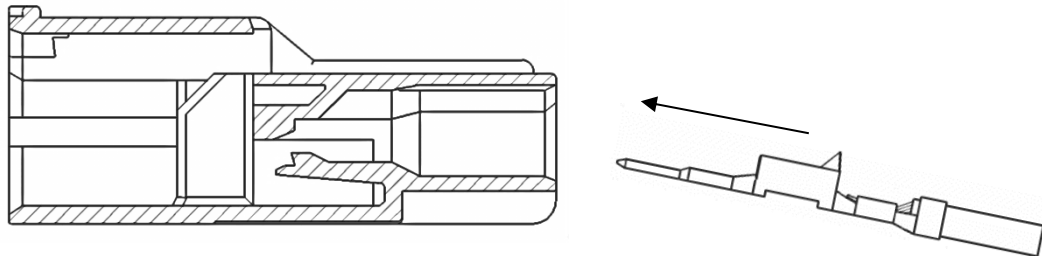
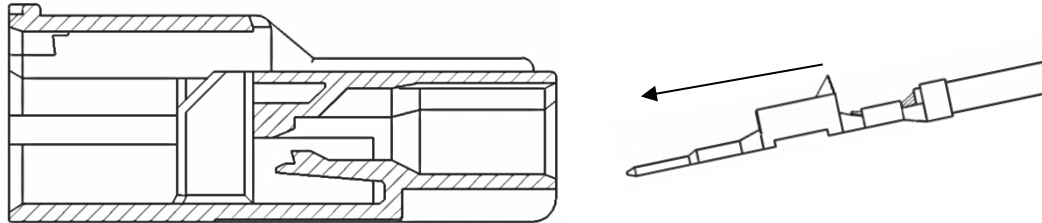

✗ Skew direction

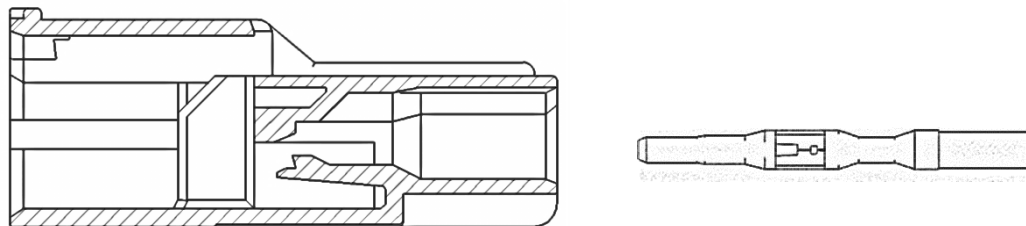
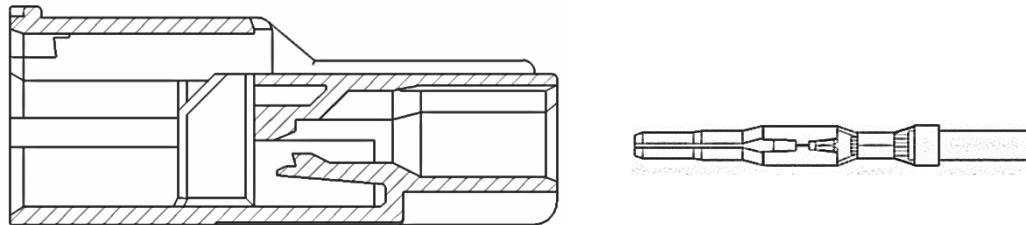

✗ Rotational direction (ex. 90°)

Fig.6-3 Inadequate insertion direction

REVISE ON PC ONLY		TITLE: CP 3.3 W/W SINGLE ROW APPLICATION SPECIFICATION	THIS DOCUMENT CONTAINS INFORMATION THAT IS PROPRIETARY TO MOLEX ELECTRONIC TECHNOLOGIES, LLC AND SHOULD NOT BE USED WITHOUT WRITTEN PERMISSION		
B	SEE SHEET 1 OF 34				
REV.	DESCRIPTION				
DOCUMENT NUMBER AS-504693-002		DOC. TYPE PS	DOC. PART 001	CUSTOMER GENERAL	SHEET 20 OF 34
EN-127(2015-12)					

- ④ After inserting the terminal, please confirm if terminals are not pulled out from receptacle housing by pulling wires lightly (with about 100g force)
(Confirmation by excessive tension might break connector.)
- ⑤ After inserting all terminals, please confirm the position of terminal lance part by looking through window of receptacle mold lance. If they are inserted correctly, terminal lance is at the position where terminal lance rode up mold lance properly and you can confirm clearance by shaking them axially lightly.
(Fig.6-4,6-5)

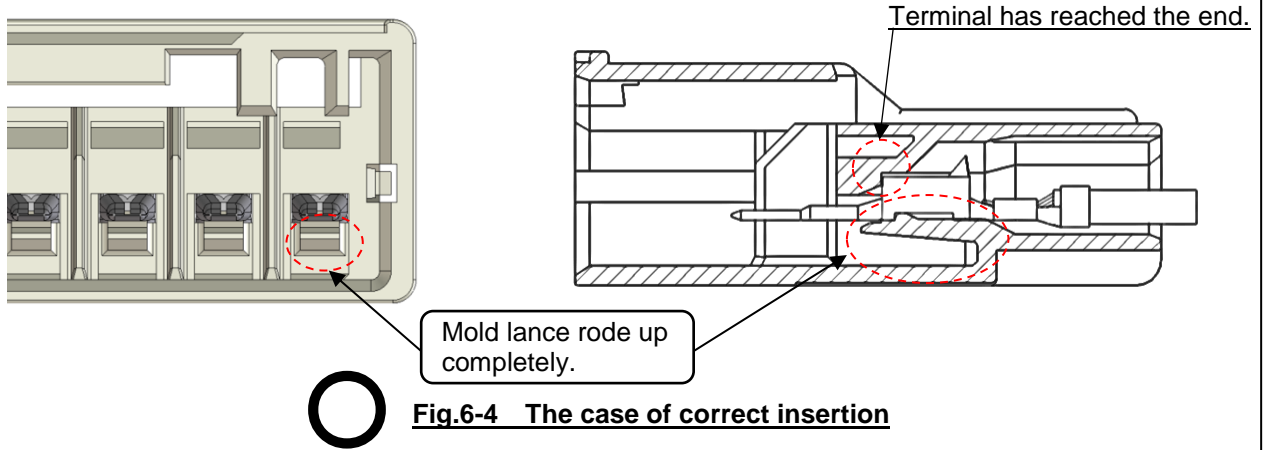

Fig.6-4 The case of correct insertion

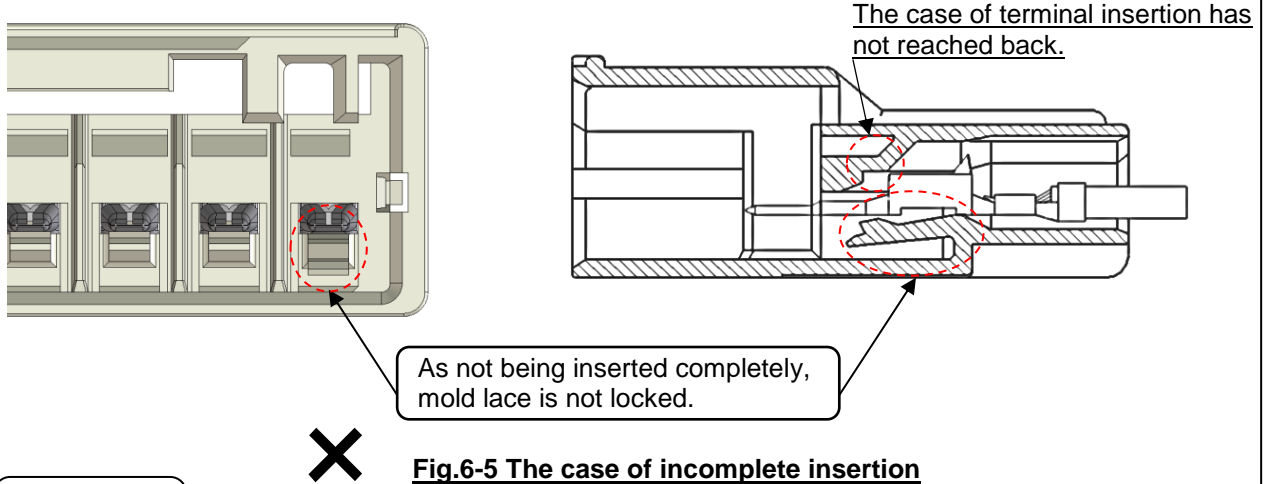

Fig.6-5 The case of incomplete insertion

Instruction

- ※If terminal is inserted incompletely, terminal lance is not locked with mold lance and terminal is not retained.
- ※In the area of incomplete insertion(see Fig.6-5), terminal lance is transformed the most. (Therefore, mold lance of harness with such condition is transformed and do not go back to correct position, resulting in degradation of retention force even though it is re-inserted.) In this case, please be sure to change with a new terminal. When checking harness after processing, please avoid bending wire excessively or with tension. That might cause contact failure because force was added to terminal crimping part or

REVISE ON PC ONLY		TITLE: CP 3.3 W/W SINGLE ROW APPLICATION SPECIFICATION			
B	SEE SHEET 1 OF 34				
REV.	DESCRIPTION	THIS DOCUMENT CONTAINS INFORMATION THAT IS PROPRIETARY TO MOLEX ELECTRONIC TECHNOLOGIES, LLC AND SHOULD NOT BE USED WITHOUT WRITTEN PERMISSION			
DOCUMENT NUMBER AS-504693-002		DOC. TYPE PS	DOC. PART 001	CUSTOMER GENERAL	SHEET 21 OF 34
EN-127(2015-12)					

receptacle housing lance part.

- ⑥ When having a conduction check, do not attach anything besides applicable mating connector. That might cause contact failure because of transformation of terminal etc.

6-2. Insertion retainer (Option)

- ① Hold housing and retainer by pinching right and left side.
- ② Please insert retainer like Fig.6-6. As shown in Fig.6-7, you can be easy to insert retainer due to skew the retainer.
- ③ The lock of retainer follows the guide lib which is shaped on the housing, Please insert retainer into housing slowly and straight until click gets held up completely.

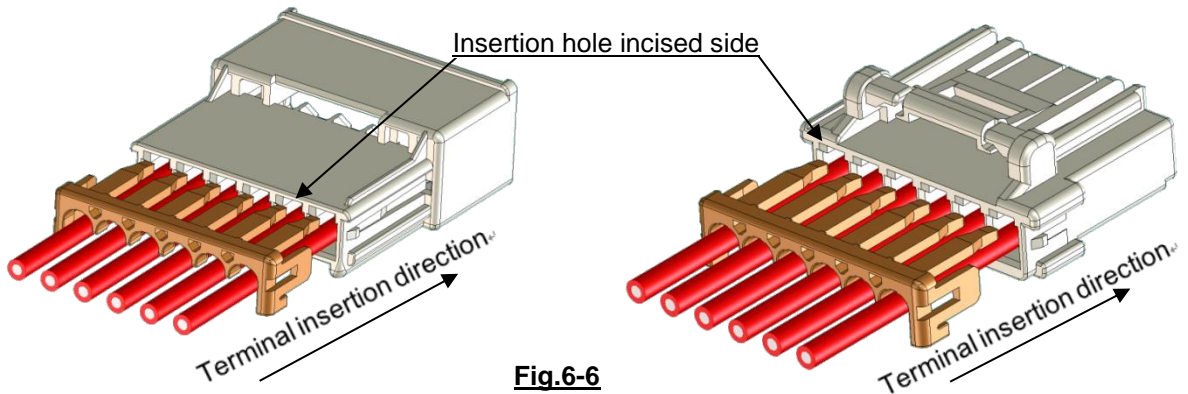

Fig.6-6

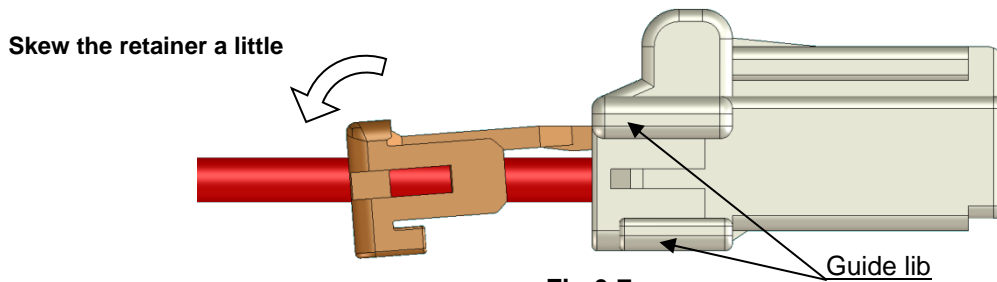

Fig.6-7

Instruction

- ※Retainer is an option. You can use housing without retainer. Retainer helps your complete insertion, and prevents from dropping terminal.
- ※If you feel unusual such as hooking during the insertion, please do not continue by force. After confirming there is no damage of retainer, it can be inserted again. If the damage is found, do not use the retainer.

REVISE ON PC ONLY		TITLE: CP 3.3 W/W SINGLE ROW APPLICATION SPECIFICATION			
B	SEE SHEET 1 OF 34				
REV.	DESCRIPTION	THIS DOCUMENT CONTAINS INFORMATION THAT IS PROPRIETARY TO MOLEX ELECTRONIC TECHNOLOGIES, LLC AND SHOULD NOT BE USED WITHOUT WRITTEN PERMISSION			
DOCUMENT NUMBER AS-504693-002		DOC. TYPE PS	DOC. PART 001	CUSTOMER GENERAL	SHEET 22 OF 34
EN-127(2015-12)					

- ④ After insert retainer, please confirm two things on your eyes.(Fig.6-8) One is the lock of retainer doesn't run on the lock of housing.(Fig.6-9) Second is retainer doesn't warp.(Fig.6-10)

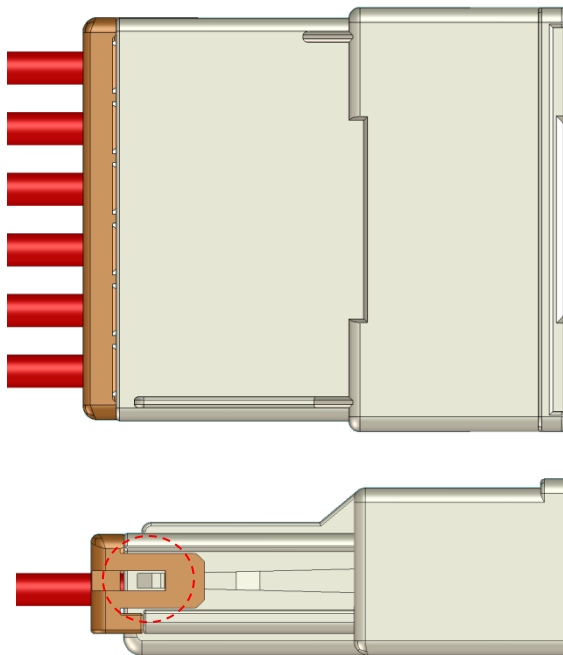

Fig.6-8 The case of correct insertion

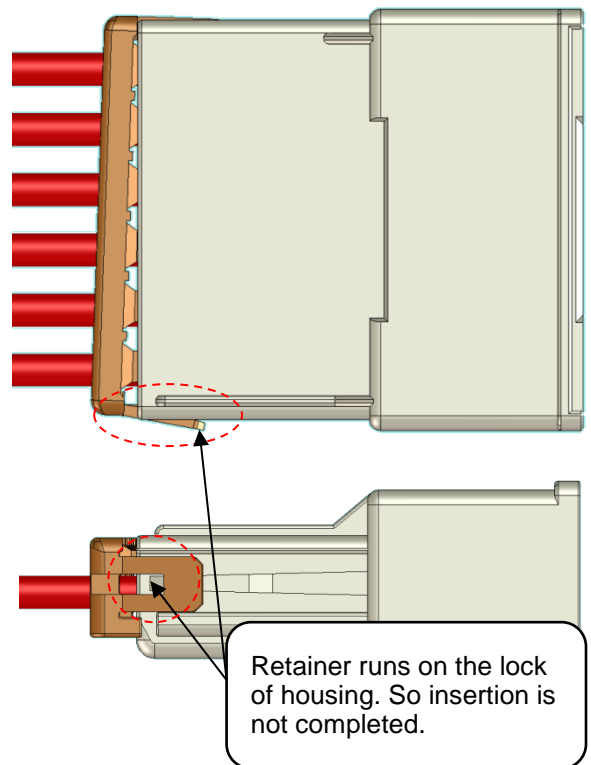

Fig.6-9 The case of running on the lock.

Retainer runs on the lock of housing. So insertion is not completed.

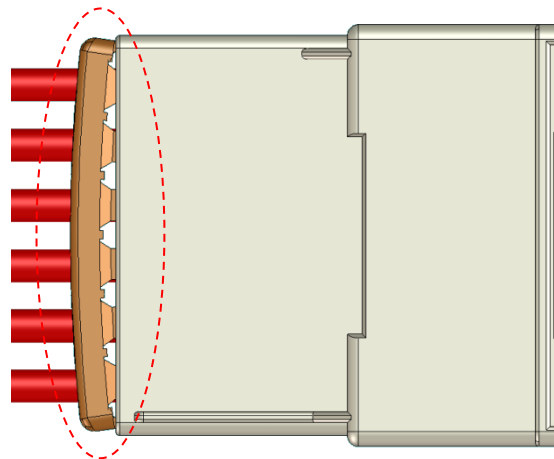

Fig.6-10 The case of warping the retainer.

REVISE ON PC ONLY		TITLE: CP 3.3 W/W SINGLE ROW APPLICATION SPECIFICATION			
B	SEE SHEET 1 OF 34				
REV.	DESCRIPTION	THIS DOCUMENT CONTAINS INFORMATION THAT IS PROPRIETARY TO MOLEX ELECTRONIC TECHNOLOGIES, LLC AND SHOULD NOT BE USED WITHOUT WRITTEN PERMISSION			
DOCUMENT NUMBER AS-504693-002		DOC. TYPE PS	DOC. PART 001	CUSTOMER GENERAL	SHEET 23 OF 34

6-3. For repairing of crimping terminal

6-3-1. Remove crimping wire from housing

When you withdraw the crimp terminal inserted once, please withdraw it with raising mold lance using the minus driver which is under $\phi 1.2$. However, mold lance is transformed by being raised. As strength of the transformed lance decreases extremely, the terminal might come off easily from housing even if you insert it again. Therefore, **please be sure to change the receptacle housing and retainer to a new one when you repair crimp terminal**. Also, please use an appropriate magnifying glass and repair with caution.

Instruction

- ※Please make condition that you can pinch the wire before repairing.
- ※Please avoid pulling off terminal by force.
- ※When repairing, please be careful not to deform or scratch terminal lance.
- ※※Please don't use the housing which is already withdrawn the terminal.

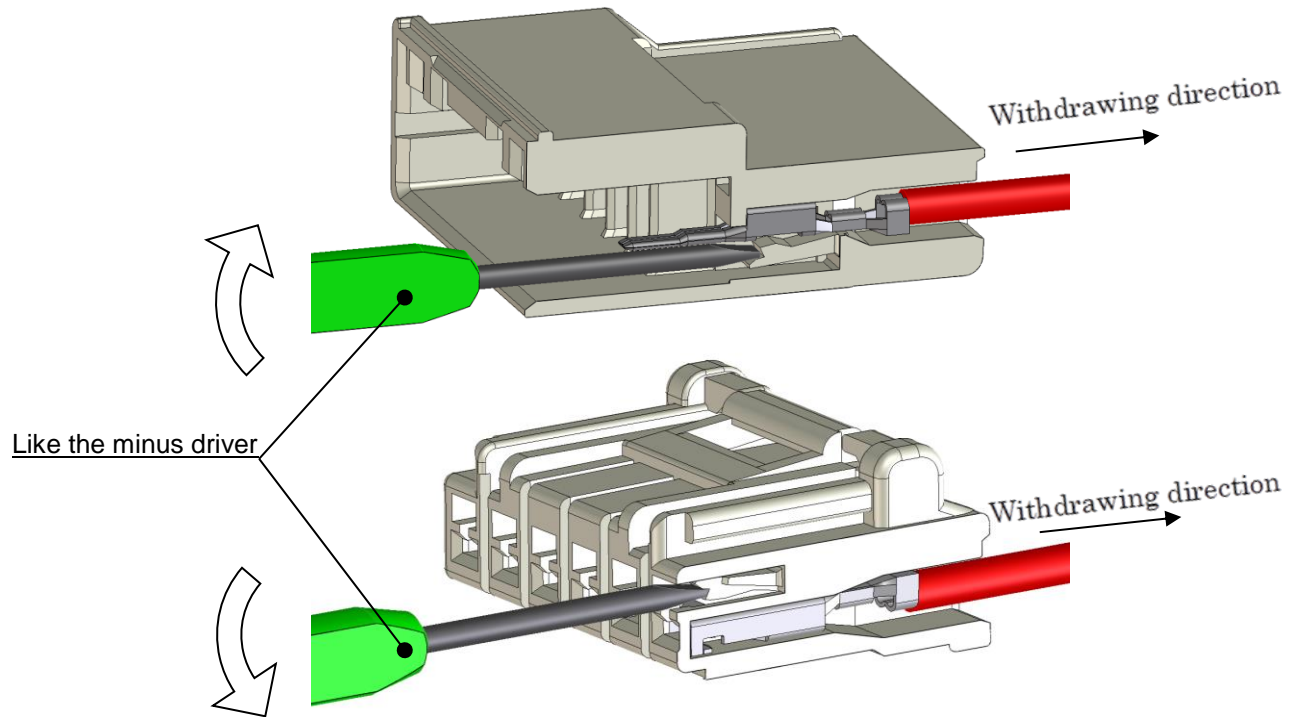

Fig.6-11

REVISE ON PC ONLY		TITLE: CP 3.3 W/W SINGLE ROW APPLICATION SPECIFICATION			
B	SEE SHEET 1 OF 34				
REV.	DESCRIPTION	THIS DOCUMENT CONTAINS INFORMATION THAT IS PROPRIETARY TO MOLEX ELECTRONIC TECHNOLOGIES, LLC AND SHOULD NOT BE USED WITHOUT WRITTEN PERMISSION			
DOCUMENT NUMBER AS-504693-002		DOC. TYPE PS	DOC. PART 001	CUSTOMER GENERAL	SHEET 24 OF 34
EN-127(2015-12)					

6-3-2. Repair of crimp terminal (Option)

When you withdraw the retainer inserted once, please withdraw it with raising lock using the minus driver which is under $\phi 3.0$. However, lock is transformed by being raised. As strength of the transformed lock decreases extremely, the retainer might come off easily from housing even if you insert it again. Therefore, please be sure to change the retainer to a new one when you repair crimp terminal.

Instruction

- ※Please make sure to run on the entire edge of retainer.
- ※Please avoid withdrawing by force. Housing, terminal and wire may be damaged.
- ※Please avoid using the retainer which is used once.

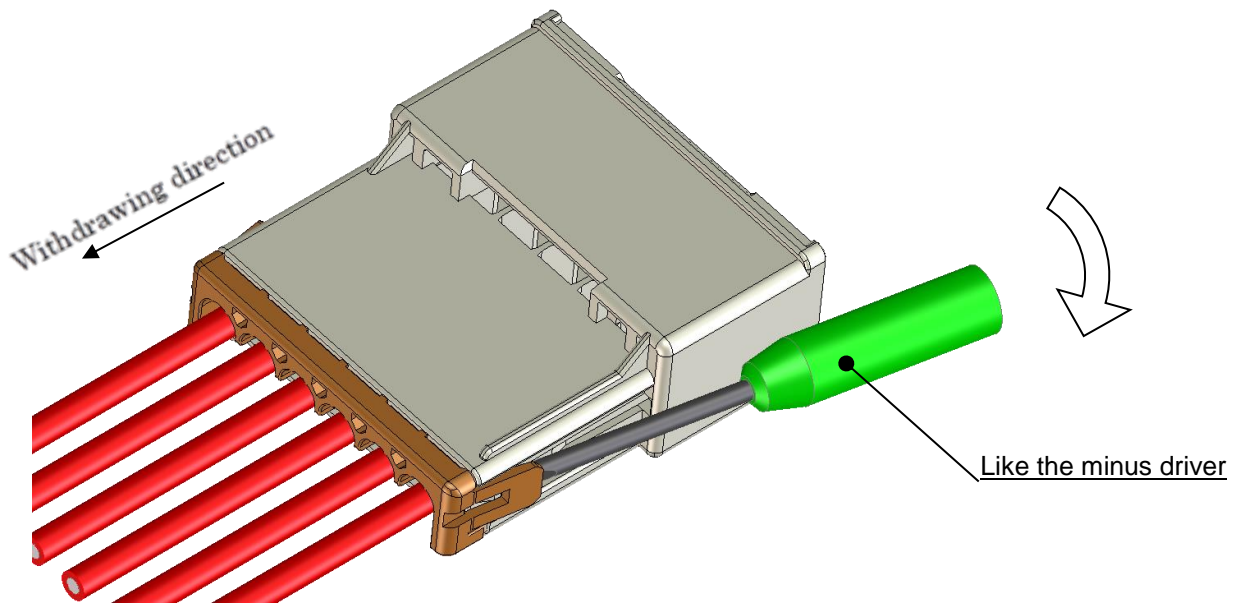

Fig.6-12

REVISE ON PC ONLY		TITLE: CP 3.3 W/W SINGLE ROW APPLICATION SPECIFICATION			
B	SEE SHEET 1 OF 34				
REV.	DESCRIPTION	THIS DOCUMENT CONTAINS INFORMATION THAT IS PROPRIETARY TO MOLEX ELECTRONIC TECHNOLOGIES, LLC AND SHOULD NOT BE USED WITHOUT WRITTEN PERMISSION			
DOCUMENT NUMBER AS-504693-002		DOC. TYPE PS	DOC. PART 001	CUSTOMER GENERAL	SHEET 25 OF 34
EN-127(2015-12)					

[7. Binding of harness]

When binding harness after processing, please be careful with the following point.

- ① Please bundle the wires at more than 35mm away from connector and uniformize the force applied to each wire. (Fig.7-1)
- ② As for the harness, please do not apply force to only one wire (or a few particular wires). (Fig.7-2)

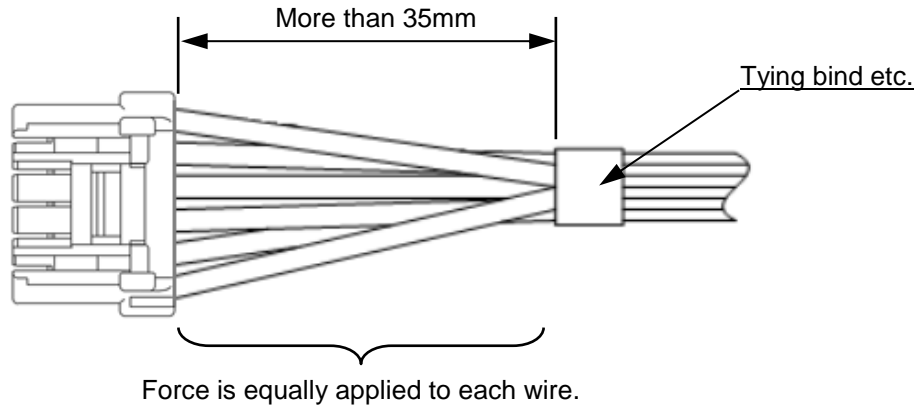

Fig.7-1 Harness is bundled properly

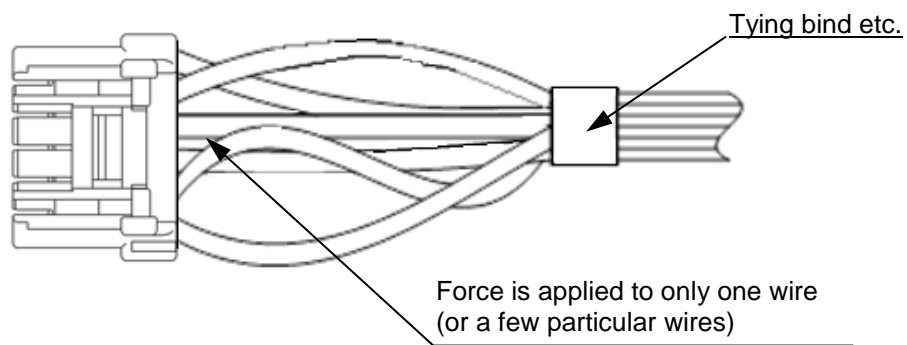

Fig.7-2 Harness is bundled improperly

Instruction

※When harness is tangled with each other, please do not pull them by force. That might cause damage to connector because extreme force is applied to terminal and it may come off from connector.

※Please do not drop the product or hit it against other objects.

REVISE ON PC ONLY		TITLE: CP 3.3 W/W SINGLE ROW APPLICATION SPECIFICATION			
B	SEE SHEET 1 OF 34				
REV.	DESCRIPTION	THIS DOCUMENT CONTAINS INFORMATION THAT IS PROPRIETARY TO MOLEX ELECTRONIC TECHNOLOGIES, LLC AND SHOULD NOT BE USED WITHOUT WRITTEN PERMISSION			
DOCUMENT NUMBER AS-504693-002		DOC. TYPE PS	DOC. PART 001	CUSTOMER GENERAL	SHEET 26 OF 34
EN-127(2015-12)					

[8. Packing method of harness]

When binding harness after processing, please be careful with the following point.

- ① Bundle the harness after processing. **Please bind 20 harnesses at most in one bunch.**

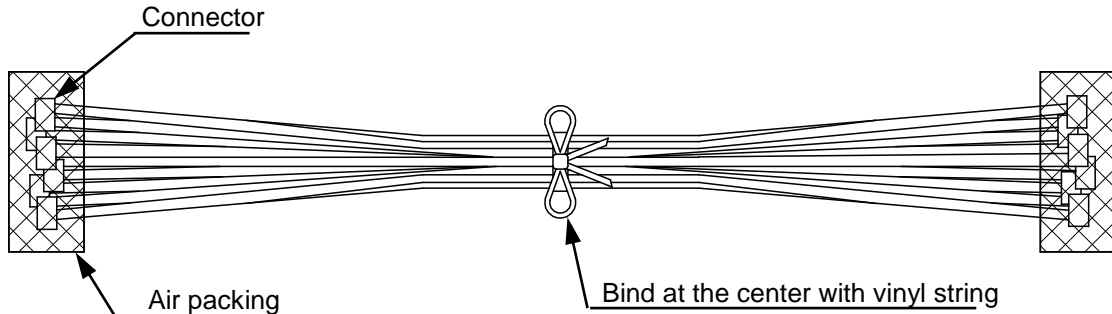

Fig.8-1 A bunch of harness

Instruction

※When bundle the harness, in order to avoid applying excessive force constantly please do not use anything that fastens tightly such as rubber bind. Please bind at the center (at one point) with vinyl string. Please take measure to protect connector from shock or load by wrapping each bunch of connector with air packing. **(Fig.8-1)**

When some harness is bundled, each connector contact and part of lock might be loaded. In that case, deformation of lock part etc. might cause defective performance because the lock being down all the time.

REVISE ON PC ONLY		TITLE: CP 3.3 W/W SINGLE ROW APPLICATION SPECIFICATION			
B	SEE SHEET 1 OF 34				
REV.	DESCRIPTION	THIS DOCUMENT CONTAINS INFORMATION THAT IS PROPRIETARY TO MOLEX ELECTRONIC TECHNOLOGIES, LLC AND SHOULD NOT BE USED WITHOUT WRITTEN PERMISSION			
DOCUMENT NUMBER AS-504693-002		DOC. TYPE PS	DOC. PART 001	CUSTOMER GENERAL	SHEET 27 OF 34
EN-127(2015-12)					

② Put bundled harnesses into carton box.

Figure below (Fig 8-2) is one of examples for recommended reference. Please take measure not to add force to connector for a long period of time by stacking if you pack by different packing method for long harness.

Instruction

※When packing bundle of harness after processing in a package box, please follow instructed packaging and avoid applying excessive load or force to harnesses. (cross shape) (Fig.8-2 ①)

※Please lay air packing etc. on the bottom of package box. In order to prevent force from applying to connectors for a long time by piling up package boxes, please lay air packing etc. (Fig.8-2 ②)

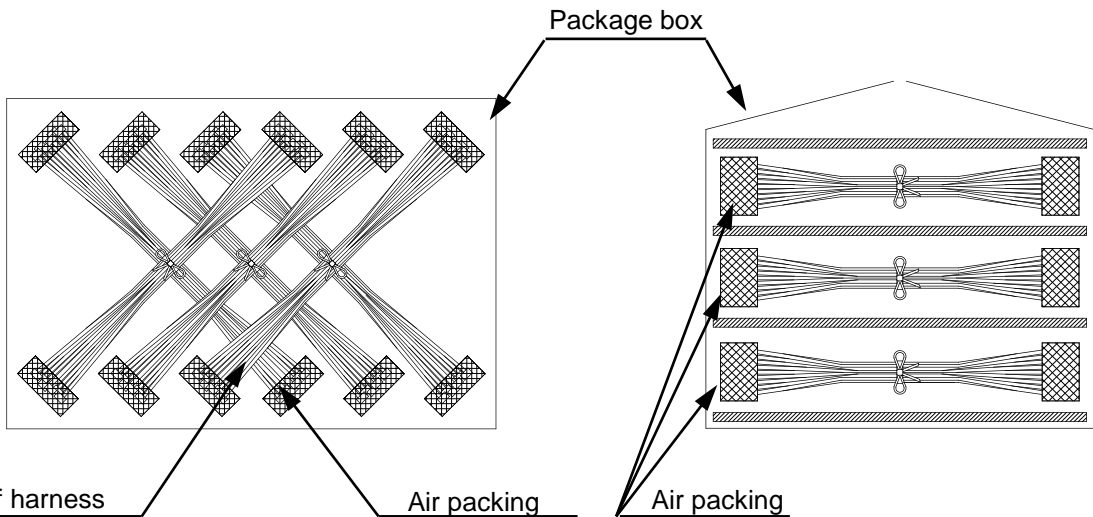
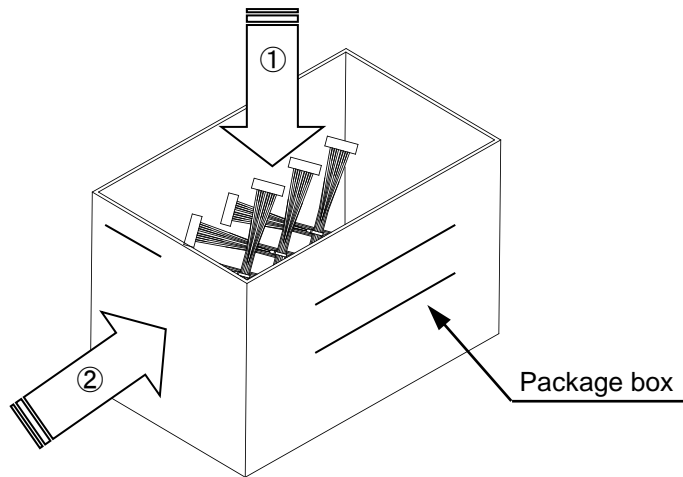

【① Packing condition from upside】

【② Packing condition from side】

Fig.8-2 Packing condition

REVISE ON PC ONLY		TITLE: CP 3.3 W/W SINGLE ROW APPLICATION SPECIFICATION			
B	SEE SHEET 1 OF 34				
REV.	DESCRIPTION	THIS DOCUMENT CONTAINS INFORMATION THAT IS PROPRIETARY TO MOLEX ELECTRONIC TECHNOLOGIES, LLC AND SHOULD NOT BE USED WITHOUT WRITTEN PERMISSION			
DOCUMENT NUMBER AS-504693-002		DOC. TYPE PS	DOC. PART 001	CUSTOMER GENERAL	SHEET 28 OF 34

[9. Instruction when mating with connector]

9-1. Mating process method

- ① Please set mating direction of receptacle housing (harness side) and plug housing (header side), and push both sides of receptacle housing to pitch direction (as shown with arrows) until both connectors meet each other (complete mating position).
- ② After mating, please confirm that lock is fastened completely.

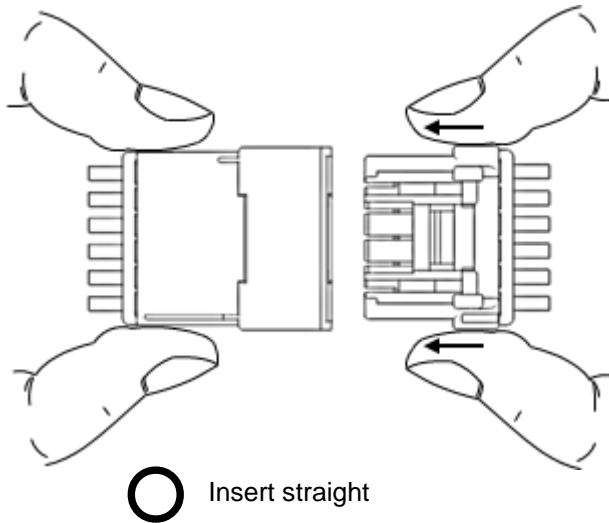

Fig.9-1

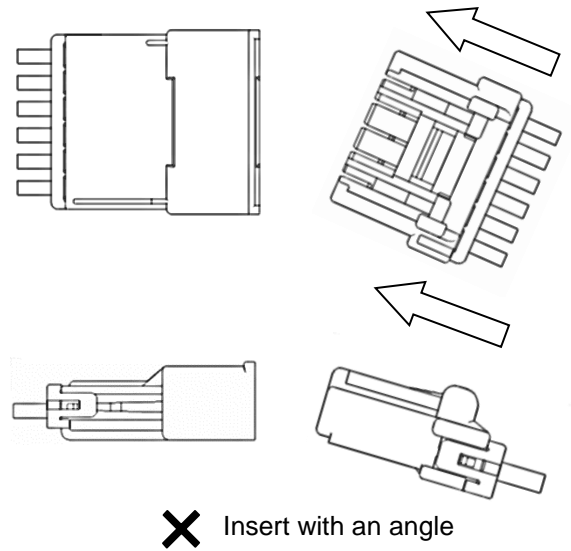

Fig.9-2

Instruction

※When mating, please do not push inner inertial lock of receptacle housing. It might cause damage by being applied excessive load by correct movement of lock part riding up the catching part is prevented.

※Please push receptacle housing and insert it straightly until they touch each other.

※If you can not insert smoothly, please insert again after confirming if there is no transformation of terminal and receptacle housing etc.

REVISE ON PC ONLY		TITLE: CP 3.3 W/W SINGLE ROW APPLICATION SPECIFICATION			
B	SEE SHEET 1 OF 34				
REV.	DESCRIPTION	THIS DOCUMENT CONTAINS INFORMATION THAT IS PROPRIETARY TO MOLEX ELECTRONIC TECHNOLOGIES, LLC AND SHOULD NOT BE USED WITHOUT WRITTEN PERMISSION			
DOCUMENT NUMBER AS-504693-002		DOC. TYPE PS	DOC. PART 001	CUSTOMER GENERAL	SHEET 29 OF 34
EN-127(2015-12)					

※ After insertion, please confirm while connector doesn't come off when you pull the all wires(200~300gf). On this occasion, you try not to pull a specific wire. Then unlock position of the receptacle housing must be original position. If position is not returned, housing may be mated incompletely. Please withdraw the connector by referring 9-2. section, and confirm while deformation is not.

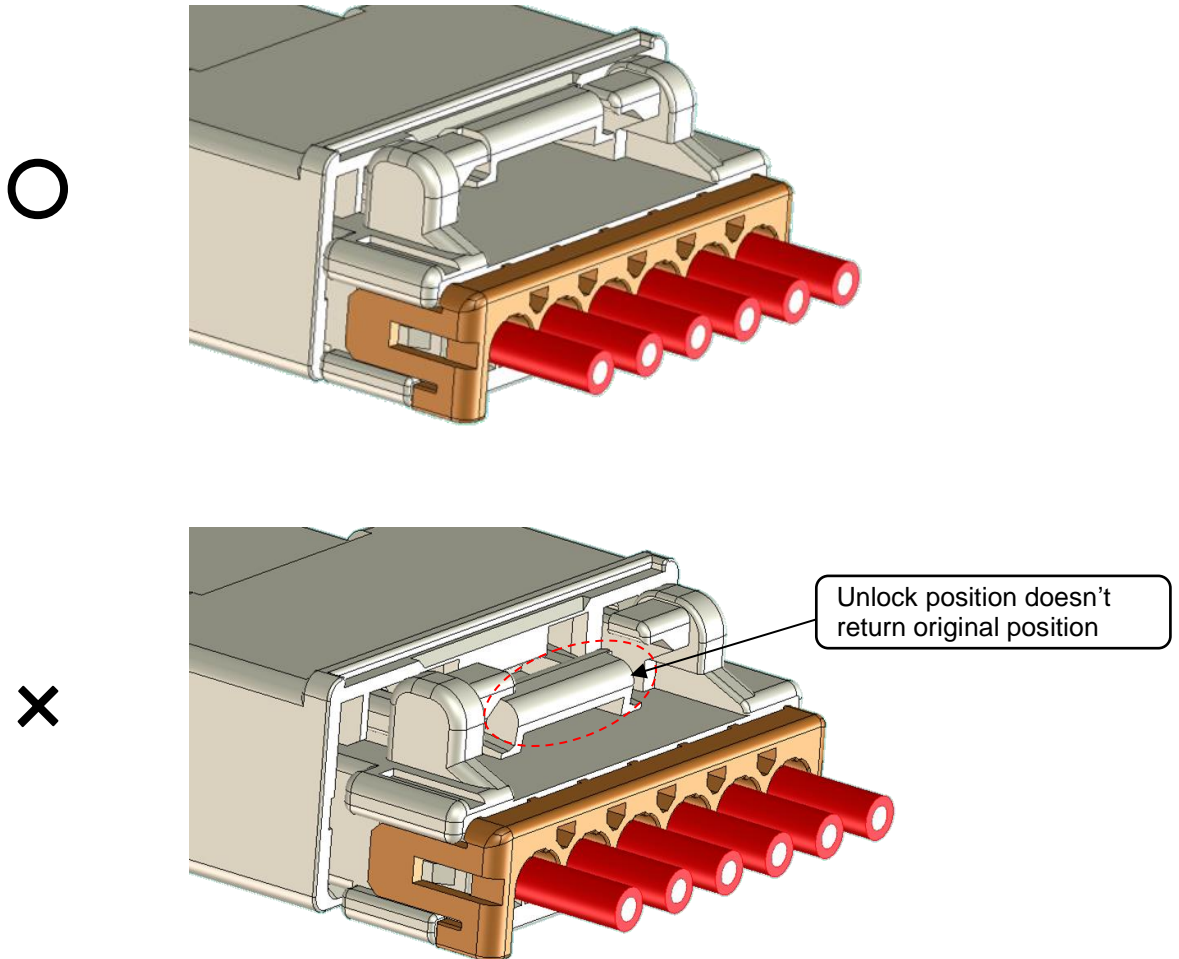

Fig.9-3 Confirming mate condition

REVISE ON PC ONLY		TITLE: CP 3.3 W/W SINGLE ROW APPLICATION SPECIFICATION	THIS DOCUMENT CONTAINS INFORMATION THAT IS PROPRIETARY TO MOLEX ELECTRONIC TECHNOLOGIES, LLC AND SHOULD NOT BE USED WITHOUT WRITTEN PERMISSION		
B	SEE SHEET 1 OF 34				
REV.	DESCRIPTION				
DOCUMENT NUMBER AS-504693-002		DOC. TYPE PS	DOC. PART 001	CUSTOMER GENERAL	SHEET 30 OF 34
EN-127(2015-12)					

9-2. Recommended de-mating method

Please hold wires all together lightly. After releasing lock completely by attaching fingers to the lock and pushing bar for releasing lock using flat part of finger, please withdraw receptacle housing slowly, axially and straightly. Please avoid withdrawing them with an angle and roughly. That might cause damage to connector.

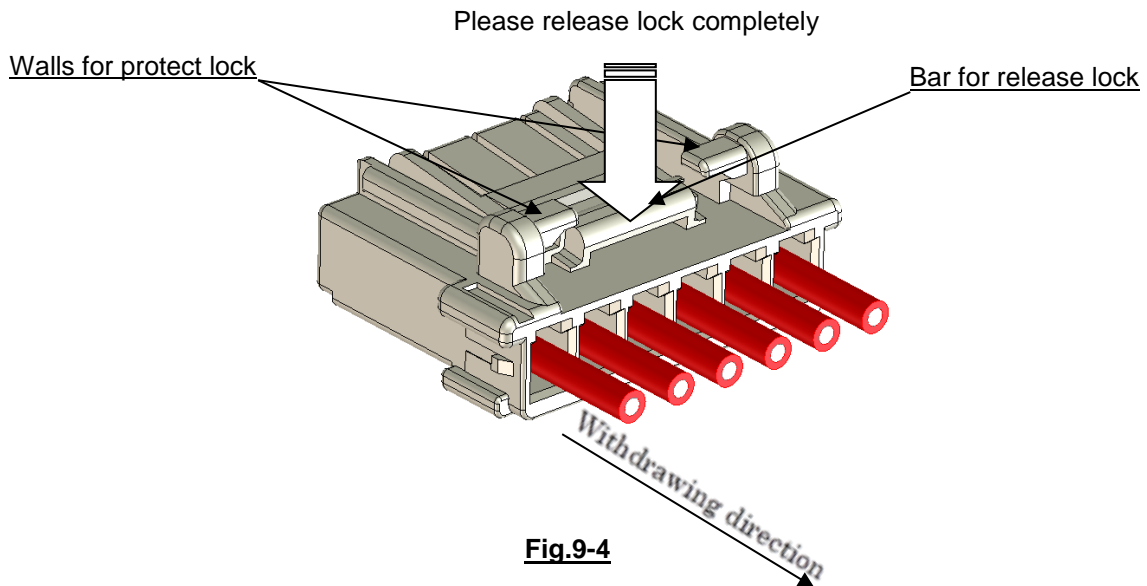

Fig.9-4

Instruction

※Please do not withdraw with holding only a few particular wires. As excessive force is applied to particular terminals, connector might be damaged or terminal might come off.

※When withdrawing, please release lock completely. This product depends on the positive lock to prevent connector from withdrawing. If you try to withdraw by force in case of locked incompletely, connector might be damaged.

REVISE ON PC ONLY		TITLE: CP 3.3 W/W SINGLE ROW APPLICATION SPECIFICATION			
B	SEE SHEET 1 OF 34				
REV.	DESCRIPTION	THIS DOCUMENT CONTAINS INFORMATION THAT IS PROPRIETARY TO MOLEX ELECTRONIC TECHNOLOGIES, LLC AND SHOULD NOT BE USED WITHOUT WRITTEN PERMISSION			
DOCUMENT NUMBER AS-504693-002		DOC. TYPE PS	DOC. PART 001	CUSTOMER GENERAL	SHEET 31 OF 34
EN-127(2015-12)					

9-3. Wiring after mating

Instruction

※Connector is not placed near the oscillatory source. Then, please fix the connector and wires. (Fig.9-5)

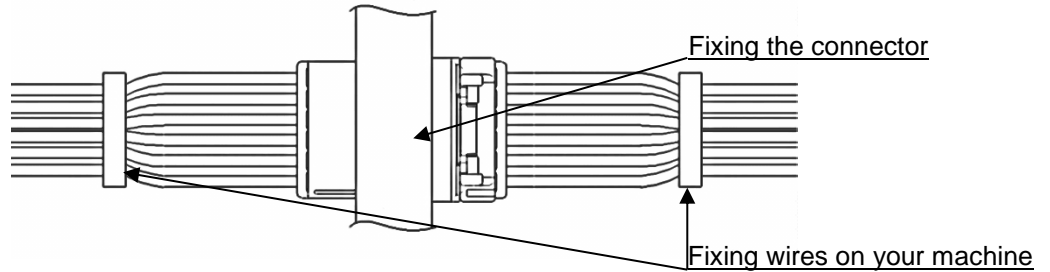

Fig.9-5 Fix inside machine

※ If you plan on pulling around wires inside machine, please take measures to prevent force from applying to connectors directly, such as allowing wires to have enough flexibility. (Fig.9-5)

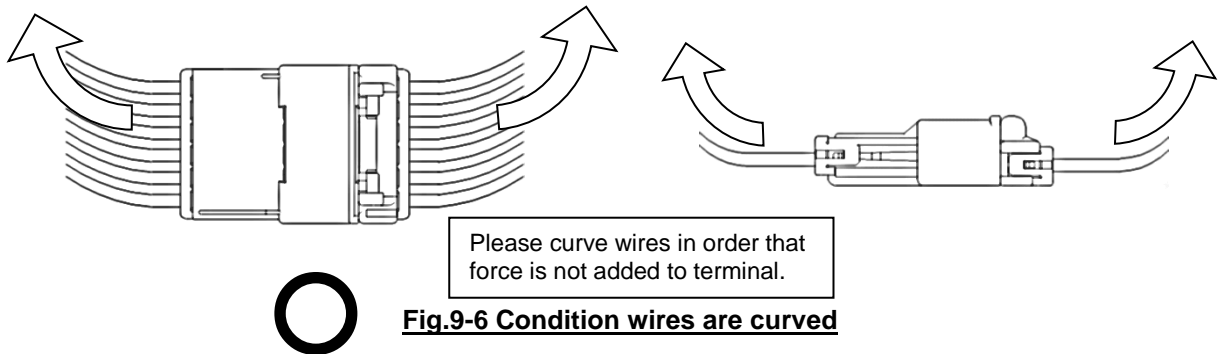

Fig.9-6 Condition wires are curved

※When pulling wires around inside actual machine, please do not use under the condition that wires are bent excessively or tension is added. That might be reason for terminal to be pulled out because force is added to terminal crimping zone or terminal insertion portion of receptacle by wire tension. Especially, please prevent force from being applied to only a few particular wires. (Fig.9-7)

※If force is added to one particular wire, wire(crimp terminal) might be pulled off.

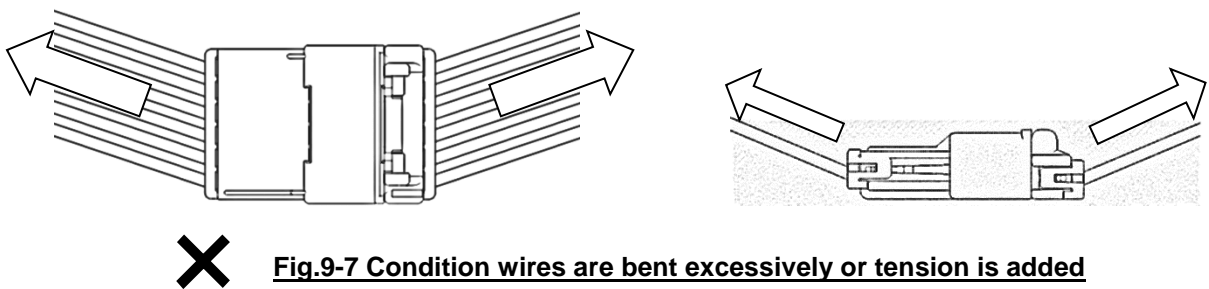

Fig.9-7 Condition wires are bent excessively or tension is added

REVISE ON PC ONLY		TITLE: CP 3.3 W/W SINGLE ROW APPLICATION SPECIFICATION			
B	SEE SHEET 1 OF 34				
REV.	DESCRIPTION	THIS DOCUMENT CONTAINS INFORMATION THAT IS PROPRIETARY TO MOLEX ELECTRONIC TECHNOLOGIES, LLC AND SHOULD NOT BE USED WITHOUT WRITTEN PERMISSION			
DOCUMENT NUMBER AS-504693-002		DOC. TYPE PS	DOC. PART 001	CUSTOMER GENERAL	SHEET 32 OF 34

※Wire routing inside customer's device needs to avoid excessive stress. Please avoid pulling them toward more than 2 directions. (Fig.9-8)

※ If you plan on special wiring inside customer's device(Fig.9-7,9-8 etc.), please contact us before using.

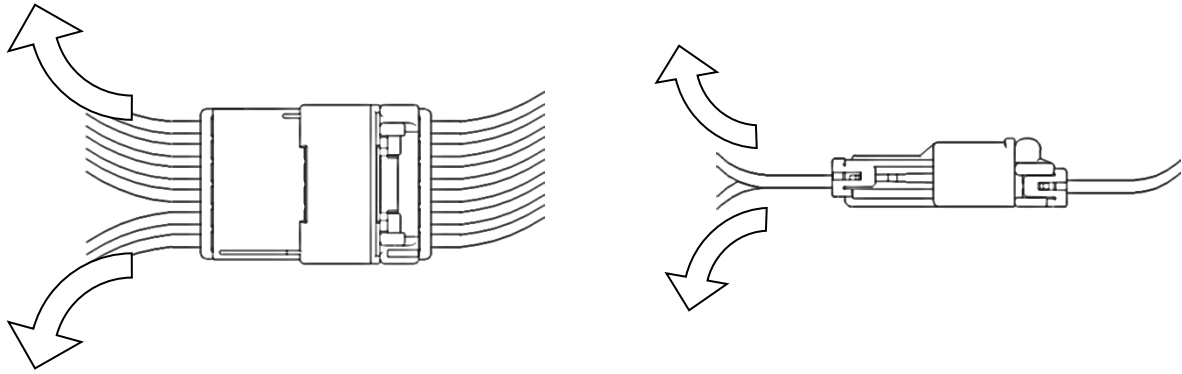

Fig.9-8 Wiring toward more than 2 direction.

REVISE ON PC ONLY		TITLE: CP 3.3 W/W SINGLE ROW APPLICATION SPECIFICATION			
B	SEE SHEET 1 OF 34				
REV.	DESCRIPTION	THIS DOCUMENT CONTAINS INFORMATION THAT IS PROPRIETARY TO MOLEX ELECTRONIC TECHNOLOGIES, LLC AND SHOULD NOT BE USED WITHOUT WRITTEN PERMISSION			
DOCUMENT NUMBER AS-504693-002		DOC. TYPE PS	DOC. PART 001	CUSTOMER GENERAL	SHEET 33 OF 34
EN-127(2015-12)					

REV.	REV. RECORD	DATE	ECN NO.	WRITTEN BY :	CHECKED BY :
A	RELEASED	'14/12/05	J2015-0753	T.AKAIKE	K.ASAKAWA
B	REVISED	'17/09/07	118386	N.ITO	S.AKIYAMA

REVISE ON PC ONLY		TITLE: CP 3.3 W/W SINGLE ROW APPLICATION SPECIFICATION			
B	SEE SHEET 1 OF 34				
REV.	DESCRIPTION				
THIS DOCUMENT CONTAINS INFORMATION THAT IS PROPRIETARY TO MOLEX ELECTRONIC TECHNOLOGIES, LLC AND SHOULD NOT BE USED WITHOUT WRITTEN PERMISSION					
DOCUMENT NUMBER AS-504693-002		DOC. TYPE PS	DOC. PART 001	CUSTOMER GENERAL	SHEET 34 OF 34
EN-127(2015-12)					