

P/N: FAPL10L-203Y0R5

Mechanical Dimensions : (mm)

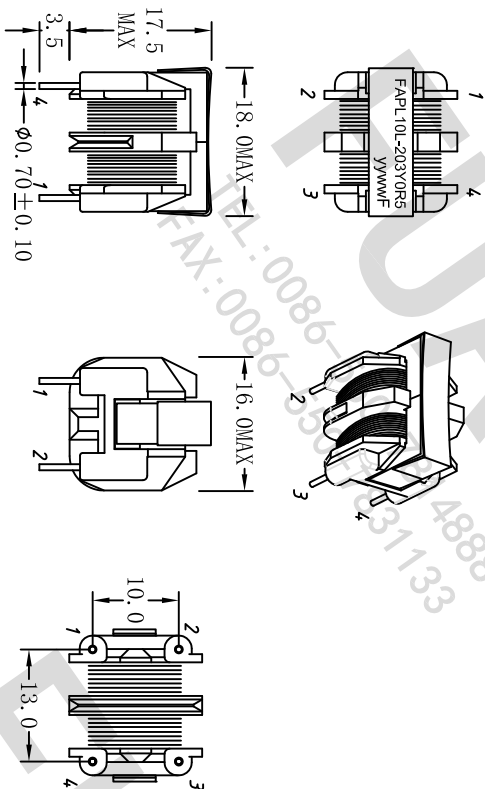

Coil structure and schematic

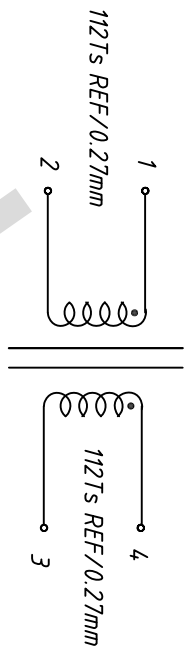

Winding Construction:

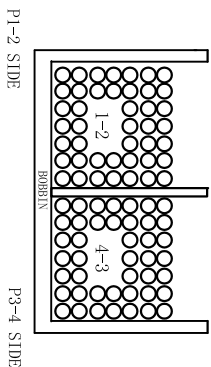

Note : Temp 20°C 48% RH. RoHS compliant.

PROPRIETARY Document is the property of FUJIAN Inc & is not allow to be duplicated without authorization

审核:

编制:

Date	Rev	Revisions Rec.

Electrical Specifications:

Inductance : L1-2&4-3 20.0mH Min @10KHz 0.1V

Rated current: 0.50A.

RDC : 1-2&4-3 150 Ohm MAX

Hi-Pot : Coil-Coil-Core 2000VAC/1mA/60Second

Bobbin: UU10.5-4P/T375J.

core: UU10.5-H10K

wire: UEW-B.

Varnish: T4260GK

<p>TEL: +86-550-7814888 Fax: +86-550-7831133 www.fujiantronics.com</p>	Model:	UU10.5 common choke	Document No:	1203002	
	Unless Otherwise Specified TOLERANCES: .X : ±0.50 .XX : ±0.25 Dimensions in mm	DWN .	Benson.zhan	Rev.: 01	DATE:
	CHK .	Anson.zhan		DATE:	Jun./12/2012
	APP .	Louis.Lin		Page No.: 1 OF 1	

文件编号: FA/QM-0303CP1784