

COLOR DOME CAMERA

SD10SCM800-130

► CAUTION

- Do not open or strike this equipment. Sensitive electronics inside are vulnerable to excessive shock.
- Do not install the equipment near any naked flames or heat sources. Excessive heat could damage this unit.
- Do not cover cloth or to install this unit in poorly ventilated places. This may lead to overheating.
- Do not continue to operate if there appears to be fault.
If the unit ceases to function, contact qualified service personnel for help.
- Do not touch the power connection with wet hands. Risk of short circuit or electric shock.
- Do not damage the power cord or leave it under pressure. Risk of fire or shock circuit.

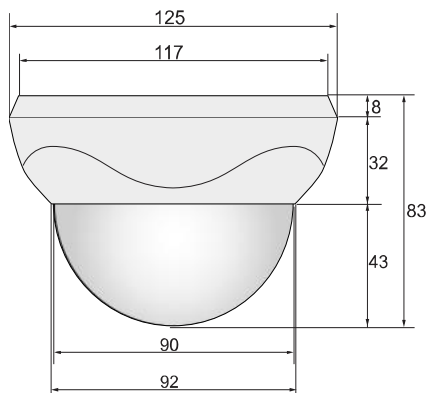

FEATURE

1/3" COLOR SONY SUPER HAD NORMAL RESOLUTION (100Φ)

- 400TV Line
- Minimum Illumination : 0.1Lux (F:1.2)
- Auto White Balance
- Automatic Gain Control
- Dimension(mm) : Φ(90+125) X 83 mm
- Power Source : DC 12.0V (9V - 15V)
- Standard 500mm, RCA/DC Jack

SPECIFICATION	SD10SCM800-130(NTSC)	SD10SCM800-130 (PAL)
Image Device	1/3" COLOR SONY SUPER HAD CCD	
Picture Elements	512(H)×492(V)	512(H)×582(V)
Scanning System	525 Lines, 2:1 Interlace	625 Lines, 2:1 Interlace
Sync System	Internal Synchronization	
Horizontal Resolution	400 TV Line	
Video Output	1Vp-p 75Ω	
S/N Ratio	More Than 50dB (AGC Off)	
Electronic Shutter	Auto	
BLC	Off	
Gamma Characteristic	Internal Synchronization: selectable (0.05-1.00)	
AGC	On	
Flickerless	Off	
LENS	2.97mm	
Smear Effect	0.005%	
Minimum Illumination	0.1Lux(F:1.2)	
Power Consumption	Regulated DC 12.0V (9V - 15V), 100mA	
Operation Temperature	-10°C - + 50°C, RH95% Max (14°F-122°F)	
Storage Temperature	-20°C - + 60°C, RH95% Max	
Weight	Approx g	
Housing	P.C / ABS Resin(body)	
Dimension(mm)	Φ(90+125) X 83 mm	
Cable(option)	Standard 500mm RCA/DC Jack	