

THIS DRAWING IS UNPUBLISHED.

RELEASED FOR PUBLICATION

.19

© COPYRIGHT 19

BY AMP INCORPORATED. ALL RIGHTS RESERVED.

LOC  
GA

DIST  
1

REVISIONS

P	LTR	DESCRIPTION	DATE	DWN	APVD
	C	REVISED PER EC LC20-0026-01	14JUN01	CD	BJ

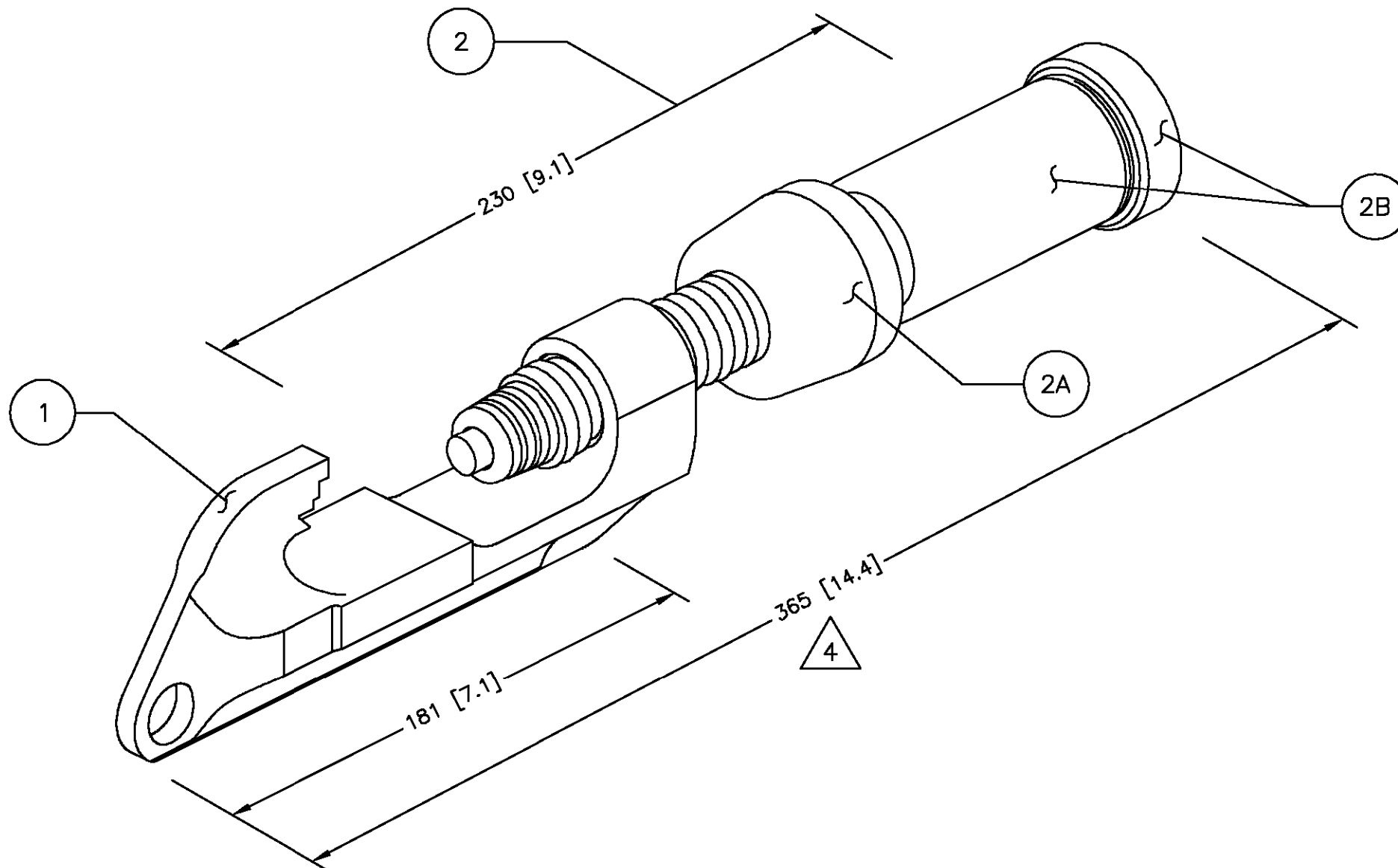

- FOR INSTALLATION OF RED, WHITE AND BLUE AMPACT TAPS.
- REFER TO CUSTOMER MANUAL 409-2106 FOR INSTRUCTIONS ON PROPER USE AND MAINTENANCE OF TOOLING.
- DIMENSIONS ARE FOR REFERENCE ONLY.
- MAXIMUM OPERATING LENGTH.
- WEIGHT: 2.36 KG [5.20 LBS].
- AMPACT CLEANING TOOL AND TAKE OFF CLIP ASSEMBLY ARE NOT SHOWN IN THE DRAWING.

C	1	-	RED & BLUE TAKE OFF CLIP ASSEMBLY & RED PLATFORM	4
C	-	1	WHITE & BLUE TAKE OFF CLIP ASSEMBLY	4
	1	1	AMPACT CLEANING TOOL	3
			BREECH CAP ASSEMBLY	2B
	1	1	BREECH ASSEMBLY	2A
			UNIVERSAL POWER UNIT	2
	1	1	SMALL TOOL HEAD	1
	-3	-	DESCRIPTION	ITEM

THIS DRAWING IS A CONTROLLED DOCUMENT.		DWN M CHOW 04 JUN 98	AMP Tyco Electronics Canada Ltd. Markham, ON L3R 1E1												
DIMENSIONS: MM [INCHES]		CHK P CHAN 15 JUL 98	NAME SMALL AMPACT TOOL												
TOLERANCES UNLESS OTHERWISE SPECIFIED:		APVD B JOHNSON 27 JUL 98	PRODUCT SPEC												
<table border="0"> <tr><td>0 PLC</td><td>±</td></tr> <tr><td>1 PLC</td><td>±</td></tr> <tr><td>2 PLC</td><td>±</td></tr> <tr><td>3 PLC</td><td>±</td></tr> <tr><td>4 PLC</td><td>±</td></tr> <tr><td>ANGLES</td><td>±</td></tr> </table>		0 PLC	±	1 PLC	±	2 PLC	±	3 PLC	±	4 PLC	±	ANGLES	±	APPLICATION SPEC	
0 PLC	±														
1 PLC	±														
2 PLC	±														
3 PLC	±														
4 PLC	±														
ANGLES	±														
MATERIAL STEEL	FINISH	WEIGHT 5	SIZE A3	CAGE CODE 00779											
		DRAWING NO C-69437		RESTRICTED TO											
		CUSTOMER DRAWING		SCALE NTS											
		SHEET 1 OF 1		REV C											