

G4 DATA SHEET

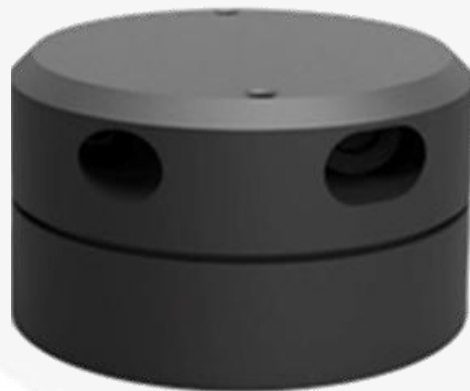

CONTENTS

1 PRODUCT OVERVIEW	1
1.1 Product Features	1
1.2 Applications	1
1.3 Installation and Dimensions	2
2 SPECIFICATIONS	2
2.1 Product Parameter	2
2.2 Electrical Parameter	3
2.3 Interface Definition	3
2.4 Data Communication	4
2.5 Optical Characteristic	4
2.6 Polar Coordinate System Definition	5
2.7 Others	5
3 REVISE	6

1 PRODUCT OVERVIEW

YDLIDAR G4 is a 360° 2D LiDAR(hereinafter referred to as G4) developed by YDLIDAR team. Based on the principle of Triangulation, it is equipped with related optics, electricity, and algorithm design to achieve high-frequency and high-precision distance measurement. The mechanical structure rotates 360° to continuously output the angle information as well as the point cloud data of the scanning environment while ranging.

1.1 Product Features

- 360° scan ranging
- High accuracy, stable performance
- Wide measuring range
- Strong resistance to ambient light interference
- Industrial grade brushless motor drive, stable performance
- Class I eye safety
- 360° omnidirectional scanning and 5-12Hz frequency
- Using optical and magnetic fusion technology to realize wireless communication and wireless power supply
- High-speed ranging, up to 9000Hz frequency

1.2 Applications

- Robot navigation and obstacle avoidance
- Industrial automation
- Regional security
- Intelligent transportation
- Environmental scanning and 3D reconstruction
- Digital multimedia interaction
- Robot ROS teaching and research

1.3 Installation and Dimensions

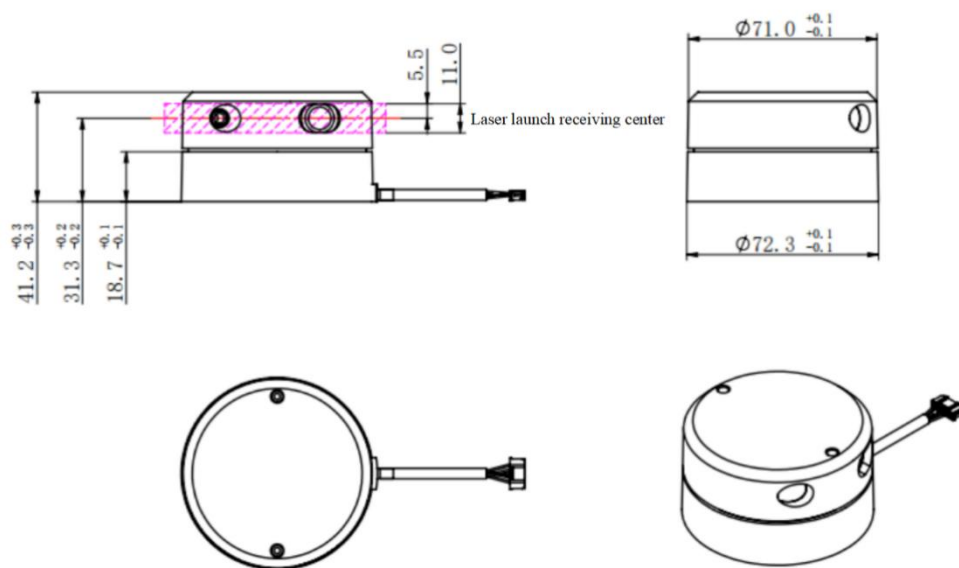

FIG 1 YDLIDAR G4 INSTALLATION&MECHANICAL SIZE

2 SPECIFICATIONS

2.1 Product Parameter

CHART 1 YDLIDAR G4 PRODUCT PARAMETER

Item	Min	Typical	Max	Unit	Remarks
Ranging frequency	/	9000	/	Hz	/
Motor frequency	5	7	12	Hz	Software speed control, default speed = 7Hz
Ranging distance	0.12	/	16	m	Ranging frequency = 4KHz (to be customized), 80% Reflectivity
	0.26	/	16	m	Ranging frequency = 8KHz(to be customized), 80% Reflectivity
	0.28	/	16	m	Ranging frequency = 9KHz, 80% Reflectivity
Fileld of view	/	0-360	/	°	/
Systematic Error	/	2	/	cm	Range≤1m
Statistical Error	/	2.0%	/	/	1m<range ≤8m

Laser pitch angle	0.25	1	1.75	°	/
Angle resolution	0.2 (Frequency @5Hz)	0.28 (Frequency @7Hz)	0.48 (Frequency @12Hz)	°	When motor frequency =7Hz, and the ranging Frequency =9000Hz

Note1: The range and relative accuracy in the above table are factory values, statistical error changes with the actual distance value.

Note2: In the above table, the relative error value represents the accuracy of the radar measurement, Statistical Error = (Ranging distance - actual distance)/ actual distance * 100%. LiDAR is a precision equipment, which needs to be protected during use. In the use scenarios of high temperature, high and low temperature or strong vibration, the parameter index of relative error will be relatively larger, and the error may exceed the than Typical value.

2.2 Electrical Parameter

CHART 2 YDLIDAR G4 ELECTRICAL PARAMETER

Item	Min	Typical	Max	Unit	Remarks
Supply voltage	4.8	5.0	5.2	V	Excessive voltage might damage the Lidar while low affect normal performance
Startup current	1000	/	/	mA	The driving capability that the power supply for the lidar needs to meet
Sleeping current	/	/	50	mA	System sleep, motor stops
Working current	/	350	500	mA	System work, motor speed=7Hz

2.3 Interface Definition

G4 provides PH2.0-5P female connector to realize power and data communication function.

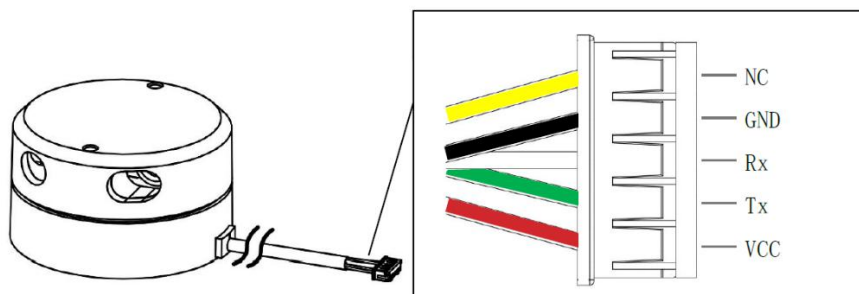

FIG 2 YDLIDAR G4 INTERFACES

CHART 3 YDLIDAR G4 INTERFACE DEFINITION

Pin	Type	Description	Defaults	Range	Remarks
VCC	Power Supply	Positive	5V	4.8V-5.2V	/
Tx	Output	System serial port output	/	/	Data stream: Lidar→Peripherals
Rx	Input	System serial port Input	/	/	Data stream: Peripherals→Lidar
GND	Power Supply	Negative	0V	0V	/
NC	Reserve	Reserved pin	/	/	/

2.4 Data Communication

With a 3.3V level serial port (UART), users can connect the external system and the product through the physical interface. After that, you can obtain the real-time scannedpoint cloud data,device information device status as well as set the device working mode, etc.The communication protocol of parameters are as follows:

CHART 4 YDLIDAR G4 SERIAL SPECIFICATION

Item	Min	Typical	Max	Unit	Remarks
Baud rate	/	230400	/	bps	8-bit data bit,1 stop bit, no parity
High Signal Level	2.4	3.3	3.5	V	/
Low signal Level	0	0.3	0.6	V	/

2.5 Optical Characteristic

G4 uses an infrared laser that meets FDA Class I eye safety standards. The laser and optical lens finish the transmission and reception of the laser signal to achieve high-frequency ranging while working. To ensure system ranging performance, please keep the laser and optical lens clean. The detailed optical parameters are as follows:

CHART 5 YDLIDAR G4 LASER OPTICAL PARAMETERS

Item	Min	Typical	Max	Unit	Remarks
Laser Wavelength	775	792	800	nm	Infrared band
Laser Power	/	3.5	6	mw	Average power
FDA	 Class I				

2.6 Polar Coordinate System Definition

In order to facilitate secondary development, G4 internally defines a polar coordinate system. The polar coordinates of the system take the center of the rotating core of G4 as the pole, and the specified Angle is positive clockwise. The zero Angle is located in the direction of the outlet of the G4 PH2.0-5P interface line (top view), which is 4° counterclockwise. Due to individual differences, there is a deviation of +/-3°, as shown in the figure:

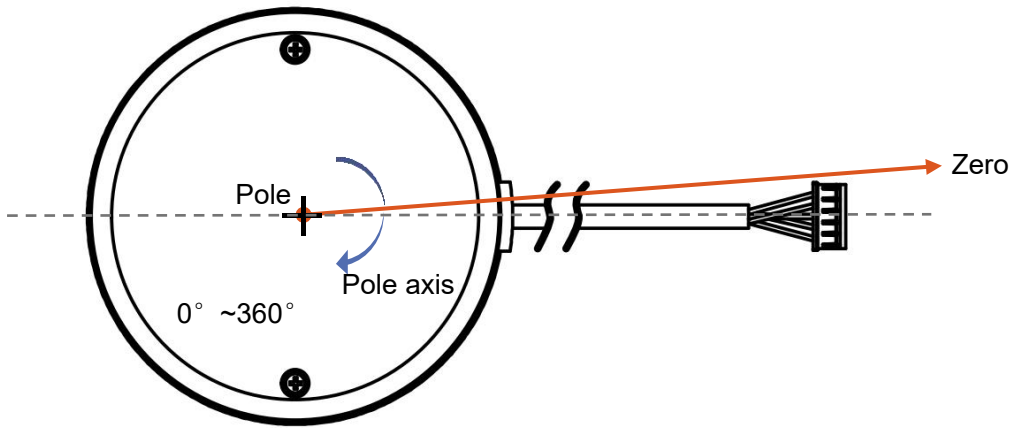

FIG 3 YDLIDAR G4 POLAR COORDINATE SYSTEM DEFINITION

Note1: When lidar is in production, the deviation of the assembly may cause the individual deviation of the zero angle of $\pm 3^\circ$.

Note2: When the Lidar is assembled on the machine, the deviation of the assembly may cause slight difference in the consistency of the zero position. For the convenience of use, we provide a zero calibration software, which can customize the zero direction and assemble to the machine. The Lidar is calibrated twice. For details, please refer to the User manual.

2.7 Others

CHART 6 YDLIDAR G4 OTHERS

Item	Min	Typical	Max	Unit	Remarks
Operating temperature	0	20	50	°C	Long-term working in a high temperature environment will reduce the life span
Storage temperature	-10	/	60	°C	/
Lighting environment	0	550	2000	Lux	For reference only
weight	/	214	/	g	/

3 REVISE

Date	Version	Content
2017-12-06	1.0	Compose a first draft
2018-01-15	1.1	Modify Operating temperature to 0-50°C, revise Interface Definition, As shown in the chart 3
2018-07-24	1.2	1) Modify ranging resolution to 1% accuracy within 8m; 2) zero angle 4° deviation
2019-02-15	1.3	1) Modify the Statistical Error; 2) Revise the footer' s period to 2015-2019
2019-03-12	1.4	Remove the USB Type-C interface, revise the page number to 7 pages, add the relative error remarks
2019-05-06	1.5	Add the range $\leq 0.5m$ error to 2cm
2019-08-27	1.6	Adjust the zero direction and the color of the line sequence
2019-09-20	1.7	Setting-up minimum distance, Add pitch angle
2019-10-16	1.8	Adjust the accuracy to 2%
2020-01-07	1.9	Optimize the presentation, Adjust the wavelength, optimize the presentation of application scenarios
2021-06-24	2.0	Modify current, temperature, power and other relevant parameters